

Memorex

MVR1026A

SERVICE MANUAL

VIDEO CASSETTE RECORDER

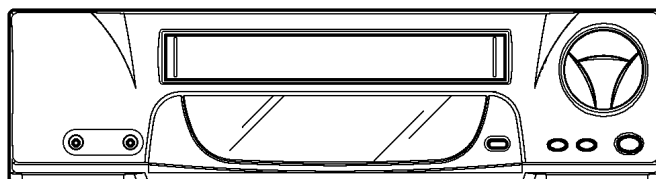

VHS

ORIGINAL
MFR'S VERSION A

SERVICING NOTICES ON CHECKING

1. KEEP THE NOTICES

As for the places which need special attentions, they are indicated with the labels or seals on the cabinet, chassis and parts. Make sure to keep the indications and notices in the operation manual.

2. USE THE DESIGNATED PARTS

The parts in this equipment have the specific characters of incombustibility and withstand voltage for safety. Therefore, the part which is replaced should be used the part which has the same character.

Especially as to the important parts for safety which is indicated in the circuit diagram or the table of parts as a  mark, the designated parts must be used.

3. PUT PARTS AND WIRES IN THE ORIGINAL POSITION AFTER ASSEMBLING OR WIRING

There are parts which use the insulation material such as a tube or tape for safety, or which are assembled in the condition that these do not contact with the printed board.

The inside wiring is designed not to get closer to the pyrogenic parts and high voltage parts. Therefore, put these parts in the original positions.

4. PERFORM A SAFETY CHECK AFTER SERVICING

Confirm that the screws, parts and wiring which were removed in order to service are put in the original positions, or whether there are the portions which are deteriorated around the serviced places serviced or not. Check the insulation between the antenna terminal or external metal and the AC cord plug blades. And be sure the safety of that.

HOW TO ORDER PARTS

Please include the following informations when you order parts. (Particularly the VERSION LETTER.)

1. MODEL NUMBER and VERSION LETTER

The MODEL NUMBER can be found on the back of each product and the VERSION LETTER can be found at the end of the SERIAL NUMBER.

2. PART NO. and DESCRIPTION

You can find it in your SERVICE MANUAL.

CONTENTS

SERVICING NOTICES ON CHECKING	A1-1
HOW TO ORDER PARTS	A1-1
CONTENTS	A2-1
GENERAL SPECIFICATIONS	A3-1~A3-6
DISASSEMBLY INSTRUCTIONS	
1. REMOVAL OF MECHANICAL PARTS AND P. C. BOARDS	B1-1
2. REMOVAL OF DECK PARTS	B2-1~B2-5
KEY TO ABBREVIATIONS	C1-1, C1-2
SERVICE MODE LIST	C2-1
PREVENTIVE CHECKS AND SERVICE INTERVALS	C3-1, C3-2
NOTE FOR THE REPLACING OF MEMORY IC	C4-1
SERVICING FIXTURES AND TOOLS	C5-1
PREPARATION FOR SERVICING	C5-1
MECHANICAL ADJUSTMENTS	D1-1~D1-4
ELECTRICAL ADJUSTMENTS	D2-1, D2-2
BLOCK DIAGRAMS	
Y/C/AUDIO/HEAD AMP	E-1, E-2
TUNER	E-3, E-4
MICON/DECK	E-5, E-6
OPERATION/POWER	E-7, E-8
PRINTED CIRCUIT BOARDS	
SYSCON/OPERATION	F-1~F-4
DECK	F-5
SCHEMATIC DIAGRAMS	
Y/C/AUDIO/HEAD AMP	G-1, G-2
TUNER	G-3, G-4
MICON	G-5, G-6
POWER	G-7, G-8
OPERATION	G-9, G-10
DECK	G-11, G-12
INTERCONNECTION DIAGRAM	G-13, G-14
WAVEFORMS	H-1
MECHANICAL EXPLODED VIEW	I-1
CHASSIS EXPLODED VIEWS	I-2, I-3
MECHANICAL REPLACEMENT PARTS LIST	J1-1
CHASSIS REPLACEMENT PARTS LIST	J2-1
ELECTRICAL REPLACEMENT PARTS LIST	J3-1, J3-2

GENERAL SPECIFICATIONS

G-1. Outline of the Product

_____ 3 _____ -Speed 1/2" Video Cassette Recorder

G-2. VCR Format

VHS Standard NTSC PAL SECAM PAL-M PAL-N
VHS Hi-Fi Audio System

G-3. Video Recording System

: Rotary, slant azimuth two head helical scan system
 Luminance Component : FM recording
 Chrominance Component: Low frequency converted direct recording

G-4. Broadcasting System

_____ US _____ System _____ M _____

G-5. Color System

NTSC PAL SECAM or Monochrome

G-6. NTSC Playback(PAL60Hz)

Yes No

G-7. MESECAM

Yes No

G-8. Cassette Tape

VHS type video cassette tape Width 12.65mm (1/2 Inch)
VHS-C type video cassette tape Width 12.65mm (1/2 Inch)

G-9. Tape Speed

NTSC or PAL-M	PAL	or	SECAM
<input checked="" type="checkbox"/> SP 33.35 mm/sec	<input type="checkbox"/> SP		23.39 mm/sec
<input checked="" type="checkbox"/> LP 16.67 mm/sec	<input type="checkbox"/> LP		11.69 mm/sec
<input checked="" type="checkbox"/> SLP 11.12 mm/sec			

G-10. Recording/Playback Time

NTSC or PAL-M

at SP Mode Max. 210 min. (with T-210 cassette)
at LP Mode Max. 420 min. (with T-210 cassette)
at SLP Mode Max. 630 min. (with T-210 cassette)

PAL or SECAM

at SP Mode Max. 300 min. (with E-300 cassette)
at LP Mode Max. 600 min. (with E-300 cassette)

G-11. Rewind/Fast Forward Time(Approx.)

FF : 1' 48" / REW :1' 48" (with E-180 cassette)

G-12. Search Speed

SP 3 and 5 Times
LP 7 and 9 Times
SLP 9 and 15 Times

G-13. Slow Speed

SP _____ Times
LP _____ Times
SLP _____ Times

G-14. Frame Advance

SP _____ Times
LP _____ Times
SLP _____ Times

G-15. Antenna Input Impedance

VHF/UHF 75 ohm unbalanced

GENERAL SPECIFICATIONS

G-16.Tuner and Receiving Channel

Tuner: Contactless Electric Tuner

Oscar(W/O HYPER) Oscar(W/ HYPER) France CATV Others

Receiving Channel

VHF (LOW) 2 ch~ 6 ch

(HIGH) 7 ch~ 13 ch

(CATV) A5 ch~ B ch C ch~ W+11 ch W+12 ch~ W+58 CH

UHF 14 ch~ 69 ch

Tuning System

Frequency syn. Voltage syn. Others

G-17.Preset Channel

No channels

Allocation ch ~ ch

 ch ~ ch

 ch ~ ch

G-18.Intermediate Frequency

Picture(FP) 45.75 MHz MHz MHz

Sound (FS) 41.25 MHz MHz MHz

FP-FS 4.50 MHz MHz MHz

G-19.RF Converter Output

Channel 3 or 4 ch. ~

Level/Impedance 66 dBμ / 75 ohm

Sound Selector Yes(G I K) No

G-20.Stereo/Dual TV Sound

Yes(NICAM GERMAN USA JAPAN) No

G-21.Tuner Sound Muting

Yes No

G-22.Video Signal

Input Level 1 Vp-p / 75 ohm

Output Level 1 Vp-p / 75 ohm

S/N Ratio 50 dB (Weighted)

Horizontal Resolution at SP Mode 230 Lines

G-23.Audio Signal

Input Level Microphone dB / Kohm

Line dB / Kohm

RCA -8 dB / 50 Kohm

Output Level Line dB / Kohm

RCA -8 dB / 1 Kohm(0dB=0.775 Vrms)

S/N Ratio at SP Mode 42 dB (Weighted)

Harmonic Distortion : 1.5 % (1KHz)

Frequency Response : at SP Mode 120 Hz ~ 10 KHz

at LP Mode 120 Hz ~ 6 KHz

at SLP Mode 120 Hz ~ 4 KHz

G-24.Heads

Video 2 Rotary Heads

FM Audio Rotary Heads

Audio / Control 1 Stationary Head (Mono Stereo(L,R))

Erase 1 Full Track Erase

G-25.Motor: 3 Motors

Tape/Cassette Loading

Cylinder (Direct Drive)

Capstan (Direct Drive)

GENERAL SPECIFICATIONS

G-26. Power Source

120 V AC 50Hz AC 60Hz

G-27. Power Consumption:

10 W at AC 120 V 60 Hz
 Stand by: 1.5 W at AC 120 V 60 Hz
 Per Year: _____ kWh / Year

G-28. Dimensions (Approx.)

360 mm(W) 240 mm(D) 95 mm(H)

G-29. Weight (Approx.)

Net : 4.0 Kg (8.8 lbs)
 Gross : 4.6 Kg (10.2 lbs)

G-30. Cabinet Material

Cabinet Front: PS 94HB DECABROM
 ABS 94V2 NON-DECA
 94V0

G-31. Cassette Loading System: Front Cassette Loading System

G-32. Tape Counter: Linear Time Tape Counter

G-33. Protector: Power Fuse Dew Sensor

G-34. Regulation

Safety

<input checked="" type="checkbox"/> UL	<input checked="" type="checkbox"/> CSA	<input type="checkbox"/> SAA	<input type="checkbox"/> SI	<input type="checkbox"/> CE	<input type="checkbox"/> SEV
<input type="checkbox"/> NEMKO	<input type="checkbox"/> FEMKO	<input type="checkbox"/> DEMKO	<input type="checkbox"/> IEC65	<input type="checkbox"/> CNS	<input type="checkbox"/> SISIR
<input type="checkbox"/> SEMKO	<input type="checkbox"/> NZ	<input type="checkbox"/> HOMOLO	<input type="checkbox"/> SABS	<input type="checkbox"/> GOST	
<input type="checkbox"/> NOM	<input type="checkbox"/> AS3159	<input type="checkbox"/> DENTORI	<input type="checkbox"/> UNE	<input type="checkbox"/> NONE	

Radiation

<input checked="" type="checkbox"/> FCC	<input checked="" type="checkbox"/> DOC	<input type="checkbox"/> PTT	<input type="checkbox"/> CE	<input type="checkbox"/> SEV
<input type="checkbox"/> SABA	<input type="checkbox"/> SI	<input type="checkbox"/> NZ	<input type="checkbox"/> HOMOLO	<input type="checkbox"/> UNE
<input type="checkbox"/> CNS	<input type="checkbox"/> CISPR13	<input type="checkbox"/> DENTORI	<input type="checkbox"/> AS/NZS	<input type="checkbox"/> NONE

G-35. Temperature

Operation 5 °C ~ 40 °C
 Storage -20 °C ~ 60 °C

G-36. Operating Humidity : Less than 80 %RH

G-37. Clock and Timer

Built-in 1 Month 8 Events Programmable Timer
 One Touch Recording : Max Time 5 Hours

G-38. Timer back up Time : More than 1/12 Minutes (at Power Off Mode)

G-39. Terminals

<input checked="" type="checkbox"/> VHF/UHF Antenna	<input type="checkbox"/> Din Type	<input checked="" type="checkbox"/> F-Type	<input type="checkbox"/> France Type
<input checked="" type="checkbox"/> Video Input(Front)	<input checked="" type="checkbox"/> Phono Jack (RCA ø8.3)	<input type="checkbox"/> BNC	
<input type="checkbox"/> Video Input(Rear)	<input type="checkbox"/> Phono Jack (RCA ø8.3)	<input type="checkbox"/> BNC	
<input checked="" type="checkbox"/> Video Output(Rear)	<input checked="" type="checkbox"/> Phono Jack (RCA ø8.3)	<input type="checkbox"/> BNC	
<input checked="" type="checkbox"/> Audio Input(Front)	<input checked="" type="checkbox"/> Phono Jack (RCA ø8.3)		
<input type="checkbox"/> Audio Input(Rear)	<input type="checkbox"/> Phono Jack (RCA ø8.3)		
<input checked="" type="checkbox"/> Audio Output(Rear)	<input checked="" type="checkbox"/> Phono Jack (RCA ø8.3)		
<input type="checkbox"/> 21 Pin			

G-40. Indicator

<input checked="" type="checkbox"/> Power (Red)	<input type="checkbox"/> Stand By ()	<input type="checkbox"/> Rec ()	<input type="checkbox"/> Repeat ()	<input type="checkbox"/> Tape In ()
<input type="checkbox"/> Kurupika Guide ()		<input type="checkbox"/> One Touch Playback ()		<input checked="" type="checkbox"/> TV/VCR (Red)
<input checked="" type="checkbox"/> REC (Red)	<input checked="" type="checkbox"/> T-REC (Red)	<input type="checkbox"/> NONE		

GENERAL SPECIFICATIONS

G-41. Display

- Fluorescent Indicator Yes No
 Clock/Counter, Channel, Timer Rec, OTR, Play, Rec, FF(Cue), Rew(Rev),
 Pause, ATR, Eject
 WKL, Y.M.D, Start, End AFT Repeat
 VCR Memory Index VPS PDC
 SP LP SLP AM PM

On Screen Display

- Menu
 Clock Set Calendar 12H 24H
 Timer Rec Set
 Auto Repeat On/Off
 CH Set TV/CATV
 Auto CH Memory
 ADD/Delete
 Sap On/Off
 No Noise Back Ground
 Language
 G-CODE(or SHOWVIEW or PLUSCODE)No. Entry
 NICAM M1/2, NICAM Off, Audio Output
 Stereo, Audio Output, Bilingual
 Stereo, Audio Output, SAP Stereo, Audio Output
 Play/Stop/FF/Rew/Rec/OTR/Pause/T-Rec (Picture)
 CH/AV Clock Memory Pin Code
 Tape Counter Index Hotel Lock Tape Speed
 Tracking TapeIn

G-42. OSD Language

- Eng Ger Fre Spa Ita Por Jan

OSD Language Setting

- Eng Ger Fre Spa Ita Por Jan
 Not Applicable

G-43. Carton

- Master Carton: Need No Need
 Content: _____ Set
 Material: _____ / _____ Corrugated Carton
 Dimensions: _____ mm(W) _____ mm(D) _____ mm(H)
 Description of Origin Yes No
 Gift Box Need No Need
 Material Single/Brown Corrugated Carton (with Photo Label)
 Single/White Corrugated Carton (with Photo Label)
 Single Full Color Carton W/Photo
 Dimensions: _____ 430 _____ mm(W) _____ 310 _____ mm(D) _____ 165 _____ mm(H)
 Design: As Per BUYER's
 Description of Origin: Yes No
 Drop Test Natural Dropping At 1 Corner / 3 Edges / 6 Surfaces
 Height 25cm 31cm 46cm 62cm 80cm 100cm
 Container Stuffing: 2,828 Sets / 40' container

GENERAL SPECIFICATIONS

G-44. Accessories

- | | |
|--|---|
| <input checked="" type="checkbox"/> Owner's Manual (<input checked="" type="checkbox"/> W/Guarantee Card) [English/French] | <input type="checkbox"/> Dew Caution Sheet |
| <input checked="" type="checkbox"/> Remote Control Unit | <input type="checkbox"/> Battery (UM- <u>4</u> x <u>2</u>) |
| <input type="checkbox"/> Video Cassette Tape | <input type="checkbox"/> Toll Free Insert Sheet |
| <input type="checkbox"/> Safety Tip | <input type="checkbox"/> Audio-Video Cord (RCA) |
| <input type="checkbox"/> Guarantee Card | |
| <input type="checkbox"/> Warning Sheet <input type="checkbox"/> Quick Set-Up Sheet | <input type="checkbox"/> U/V Mixer |
| <input type="checkbox"/> Information Sheet | <input type="checkbox"/> 75 ohm Coaxial Cable (<input checked="" type="checkbox"/> Single Shield <input type="checkbox"/> Double Shield) |
| <input checked="" type="checkbox"/> 75 ohm Coaxial Cable (<input checked="" type="checkbox"/> Single Shield <input type="checkbox"/> Double Shield) | |
| <input type="checkbox"/> 300 ohm to 75 ohm VHF Antenna Adaptor | <input type="checkbox"/> Car Cord |
| <input type="checkbox"/> 21pin Cable | |

G-45. Other Features

- | | |
|---|--|
| <input checked="" type="checkbox"/> Auto Head Cleaning | <input type="checkbox"/> Index Search |
| <input checked="" type="checkbox"/> Auto Tracking | <input type="checkbox"/> Auto Search |
| <input type="checkbox"/> CH Auto Set-Up/Auto Clock | <input type="checkbox"/> ATS |
| <input type="checkbox"/> VIDEO PLUS+, SHOWVIEW, G-CODE | <input type="checkbox"/> PDC |
| <input checked="" type="checkbox"/> HQ (VHS Standard High Quality) | <input type="checkbox"/> VPS |
| <input checked="" type="checkbox"/> Auto Power On, Auto Play, Auto Rewind, Auto Eject, Auto Power Off | <input checked="" type="checkbox"/> Full OSD |
| <input type="checkbox"/> Premiere/ Canal+ | <input type="checkbox"/> SQPB |
| <input checked="" type="checkbox"/> Forward / Reverse Picture Search | <input type="checkbox"/> SAP |
| <input type="checkbox"/> One Touch Playback | <input type="checkbox"/> Channel Lock |
| <input checked="" type="checkbox"/> CATV | <input type="checkbox"/> Anti Theft |
| <input checked="" type="checkbox"/> Auto CH Memory | <input type="checkbox"/> Hotel Lock |
| <input type="checkbox"/> Just Clock Function | <input checked="" type="checkbox"/> CM Skip(30s x 6 Times) |
| <input type="checkbox"/> Kurupika Guide | <input type="checkbox"/> Game Position |
| <input type="checkbox"/> Rental | <input checked="" type="checkbox"/> Energy Star |
| <input type="checkbox"/> Self Seeking | |

G-46. Switch

Front

- | | | |
|---|--|--|
| <input checked="" type="checkbox"/> Power | <input checked="" type="checkbox"/> Channel Up | <input checked="" type="checkbox"/> Channel Down |
| <input checked="" type="checkbox"/> Play | <input checked="" type="checkbox"/> F.FWD/Cue | <input checked="" type="checkbox"/> Rew/Rev |
| <input type="checkbox"/> Pause/Still | <input checked="" type="checkbox"/> Eject/Stop | <input checked="" type="checkbox"/> Rec/OTR |
| <input type="checkbox"/> System Select | <input type="checkbox"/> Input Select | <input type="checkbox"/> Output Select |
| <input type="checkbox"/> One Touch Playback | | |

Rear

- RF-Converter Output Channel Selector(1 or 2CH 3 or 4CH)
- TV/CATV Selector
- SIF Selector

GENERAL SPECIFICATIONS

G-47.Remote Control Unit: RC-CE

Glow in Dark Remocon Yes

No

Power Source: D.C 3 V Battery UM - 4 x 2

- | | | |
|---|---|---|
| <input checked="" type="checkbox"/> 0 | <input checked="" type="checkbox"/> Ch Up | <input checked="" type="checkbox"/> Power |
| <input checked="" type="checkbox"/> 1 | <input checked="" type="checkbox"/> Ch Down | <input type="checkbox"/> Eject |
| <input checked="" type="checkbox"/> 2 | <input type="checkbox"/> Ch Skip | <input checked="" type="checkbox"/> Play |
| <input checked="" type="checkbox"/> 3 | <input checked="" type="checkbox"/> Cancel | <input type="checkbox"/> Play/Up |
| <input checked="" type="checkbox"/> 4 | <input checked="" type="checkbox"/> Enter | <input type="checkbox"/> Play/Slow/Up |
| <input checked="" type="checkbox"/> 5 | <input checked="" type="checkbox"/> Speed | <input checked="" type="checkbox"/> F.FWD |
| <input checked="" type="checkbox"/> 6 | <input type="checkbox"/> Index | <input type="checkbox"/> F.FWD/Right |
| <input checked="" type="checkbox"/> 7 | <input type="checkbox"/> Program | <input checked="" type="checkbox"/> Rew |
| <input checked="" type="checkbox"/> 8 | <input type="checkbox"/> Program/Video Plus | <input type="checkbox"/> Rew/Left |
| <input checked="" type="checkbox"/> 9 | <input type="checkbox"/> Video Plus | <input checked="" type="checkbox"/> Pause/Still |
| <input type="checkbox"/> 10 | <input type="checkbox"/> Set Up | <input type="checkbox"/> Pause |
| <input type="checkbox"/> 11 | <input type="checkbox"/> Set Down | <input checked="" type="checkbox"/> Stop |
| <input type="checkbox"/> 12 | <input type="checkbox"/> Set Right | <input type="checkbox"/> Stop/Down |
| <input type="checkbox"/> ./. | <input type="checkbox"/> Set Left | <input checked="" type="checkbox"/> REC/OTR |
| <input checked="" type="checkbox"/> Auto Tracking | <input checked="" type="checkbox"/> Call | <input type="checkbox"/> Clock/Counter |
| <input type="checkbox"/> Jog/Shuttle | <input checked="" type="checkbox"/> Menu | <input type="checkbox"/> Counter Memory |
| <input type="checkbox"/> Dial JOG | <input checked="" type="checkbox"/> TV/VCR | <input checked="" type="checkbox"/> Counter Reset |
| <input type="checkbox"/> Ring Shuttle | <input checked="" type="checkbox"/> Timer Rec | <input type="checkbox"/> Audio Select |
| <input type="checkbox"/> One Touch Playback | <input type="checkbox"/> Audio Dubbing | <input type="checkbox"/> Skip Search |
| <input checked="" type="checkbox"/> Set Up | <input checked="" type="checkbox"/> Tracking Up | <input checked="" type="checkbox"/> Input Select |
| <input checked="" type="checkbox"/> Set Down | <input checked="" type="checkbox"/> Tracking Down | |

DISASSEMBLY INSTRUCTIONS

1. REMOVAL OF MECHANICAL PARTS AND P.C. BOARDS

1-1: TOP CABINET, FRONT CABINET AND OPERATION PCB (Refer to Fig. 1-1)

1. Remove the 4 screws ①.
2. Remove the Top Cabinet in the direction of arrow (A).
3. Disconnect the following connector: (CP651).
4. Unlock the 7 supports ②.
5. Remove the Front Cabinet in the direction of arrow (B).
6. Remove the 4 screws ③ and remove the Operation PCB.

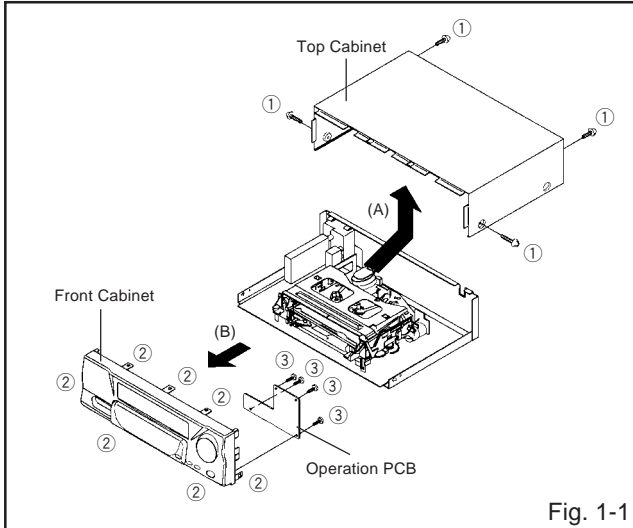

1-2: FLAP (Refer to Fig. 1-2)

1. Open Flap to 90° and flex in direction of arrow (A), at the same time slide in direction of arrow (B).
2. Then lift in direction of arrow (C).

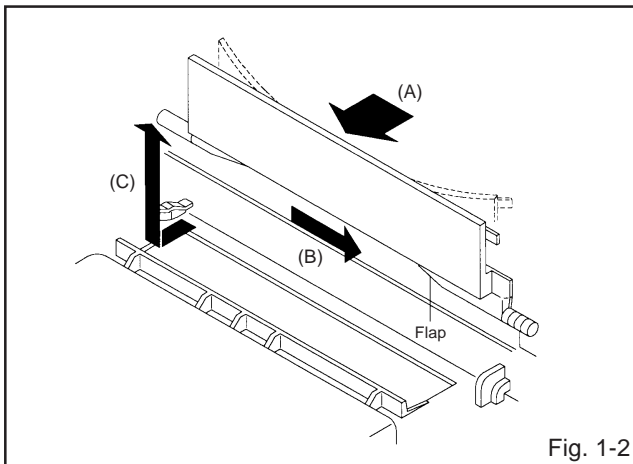

1-3: DECK CHASSIS (Refer to Fig. 1-3)

1. Remove the 3 screws ①.
2. Remove the screw ②.
3. Disconnect the following connectors: (CP1001, CP1002, CP1003, CP4001, CP4002 and CP4003).
4. Remove the Deck Chassis in the direction of arrow.

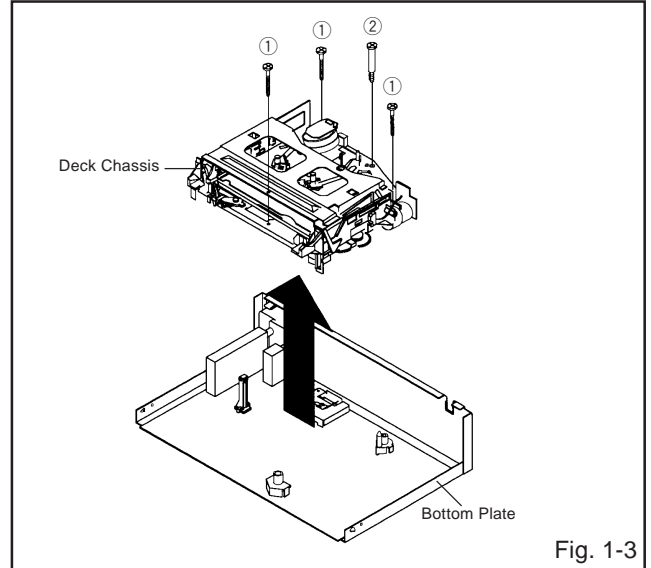

1-4: SYSCON PCB AND JACK PLATE (Refer to Fig. 1-4)

1. Remove the screw ①.
2. Remove the Syscon PCB in the direction of arrow (A).
3. Unlock the 2 supports ②.
4. Remove the Jack Plate in the direction of arrow (B).

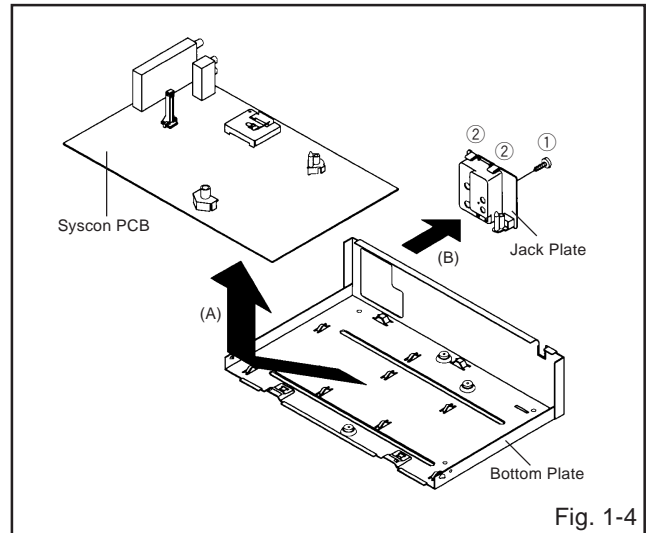

DISASSEMBLY INSTRUCTIONS

2. REMOVAL OF DECK PARTS

2-1: TOP BRACKET (Refer to Fig. 2-1)

1. Remove the 2 screws ①.
2. Slide the 2 supports ② and remove the Top Bracket.

NOTE

When you install the Top Bracket, install the screw (1) first, then install the screw (2).

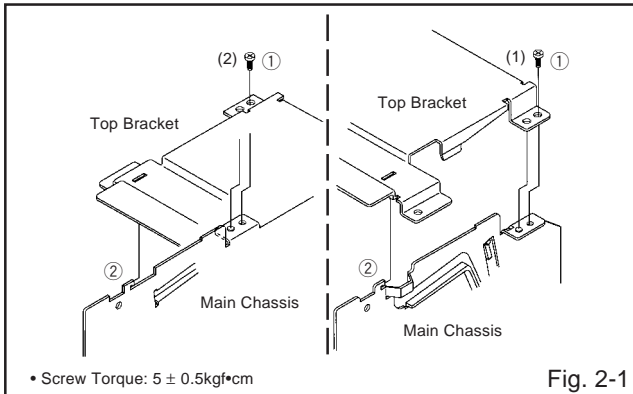

Fig. 2-1

2-2: FLAP LEVER/TAPE GUIDE R (Refer to Fig. 2-2)

1. Move the Cassette Holder Ass'y to the back side.
2. Remove the Polyslider Washer ①.
3. Remove the Flap Lever.
4. Unlock the 3 supports ② and remove the Tape Guide R.

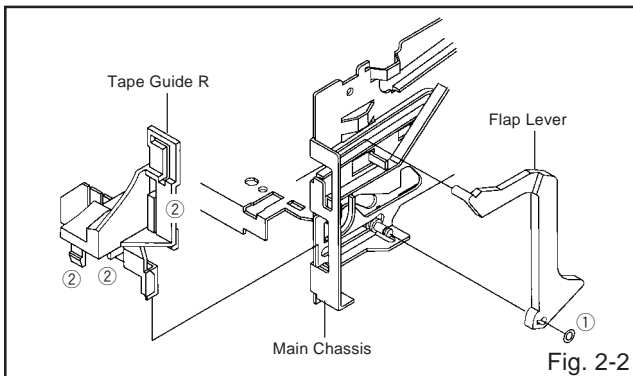

Fig. 2-2

2-3: TAPE GUIDE L (Refer to Fig. 2-3-A)

1. Move the Cassette Holder Ass'y to the back side.
2. Unlock the 2 supports ① and remove the Tape Guide L.
3. Remove the REC Lever. (Recorder only)

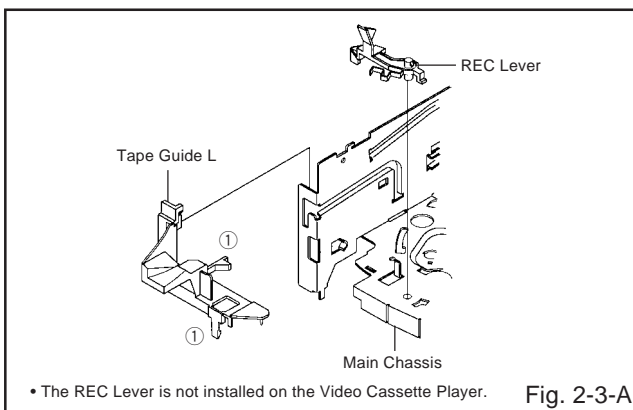

Fig. 2-3-A

NOTE

When you install the Tape Guide L, install as shown in the circle of Fig. 2-3-B. (Refer to Fig. 2-3-B)

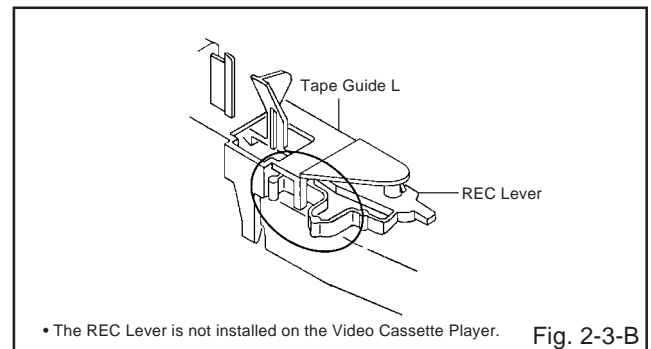

Fig. 2-3-B

2-4: CASSETTE HOLDER ASS'Y (Refer to Fig. 2-4)

1. Move the Cassette Holder Ass'y to the front side.
2. Push the Locker R to remove the Cassette Side R.
3. Remove the Cassette Side L.

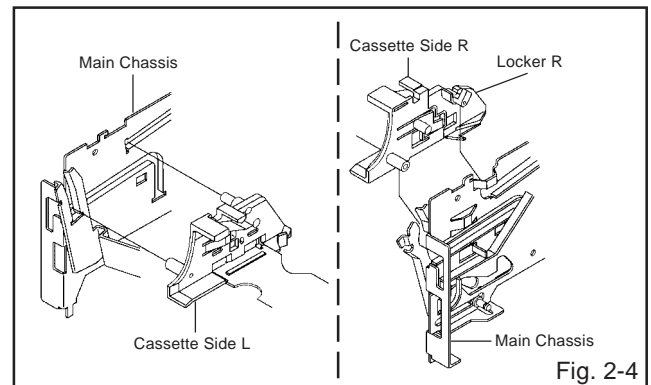

Fig. 2-4

2-5: CASSETTE SIDE L/R (Refer to Fig. 2-5)

1. Remove the Locker Spring.
2. Unlock the 4 supports ① and then remove the Cassette Side L/R.

NOTE

When you install the Cassette Side L/R, be sure to move the Locker L/R after installing.

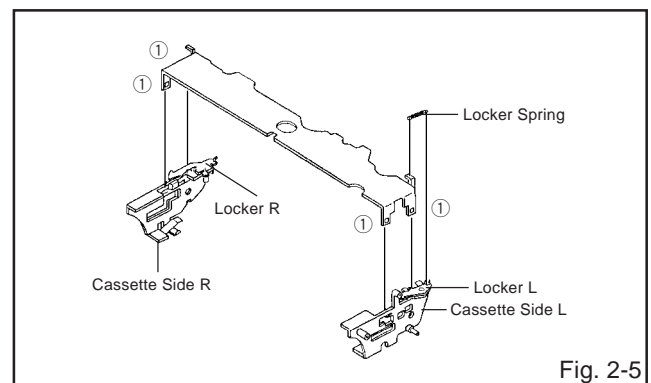
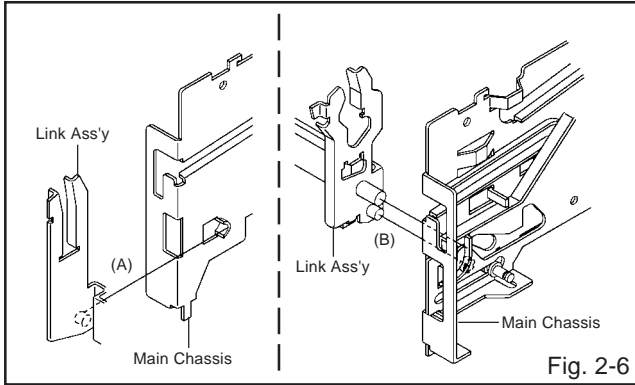

Fig. 2-5

DISASSEMBLY INSTRUCTIONS

2-6: LINK ASS'Y (Refer to Fig. 2-6)

1. Set the Link Ass'y to the Eject position.
2. Remove the (A) side of the Link Ass'y first, then remove the (B) side.



2-7: LOADING MOTOR ASS'Y (Refer to Fig. 2-7)

1. Remove the Link Lever.
2. Remove the Dumper Spring.
3. Remove the 2 screws ①.
4. Unlock the support ② and remove the Loading Motor Ass'y.
5. Unlock the 2 supports ③ and remove the Deck PCB (BOT).

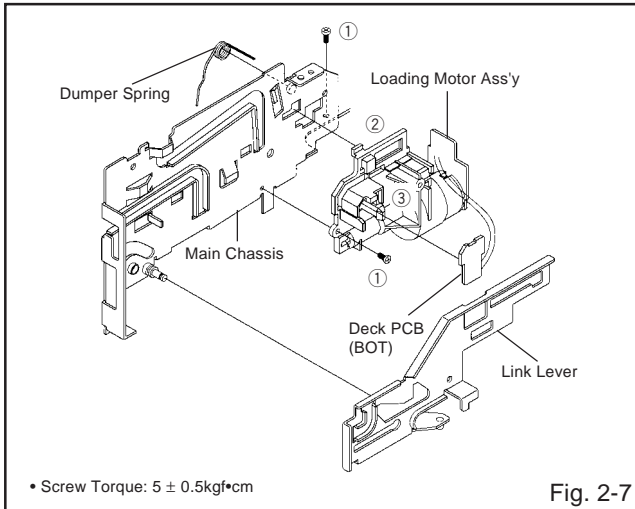

2-9: TENSION ASS'Y (Refer to Fig. 2-9-A)

1. Move the Inclined S Ass'y to the back side.
2. Remove the Tension Spring.
3. Unlock the support ① and remove the Tension Arm Ass'y.
4. Remove the Tension Adjust.
5. Unlock the 2 supports ② and remove the Tension Band Ass'y.
6. Unlock the support ③ and remove the Tension Holder.
7. Remove the SS Brake Spring.
8. Remove the SS Arm Brake.

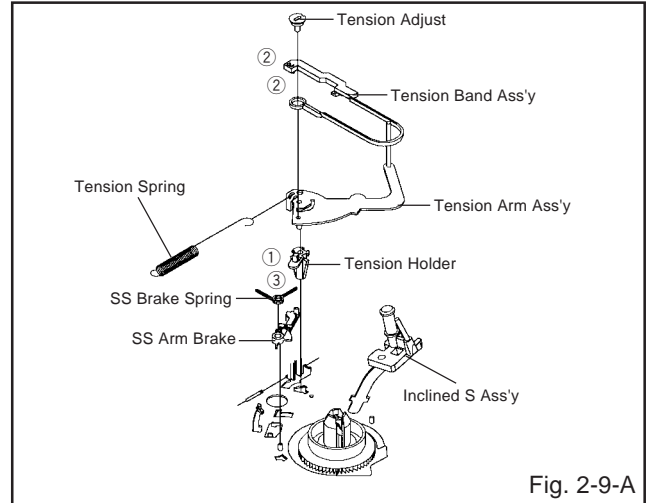

NOTE

When you install the Tension Adjust, install as shown in Fig. 2-9-B. (Refer to Fig. 2-9-B)

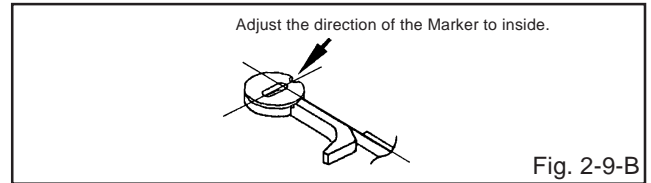

2-10: T BRAKE ASS'Y (Refer to Fig. 2-10)

1. Remove the T Brake Spring.
2. Remove the T Brake Ass'y.

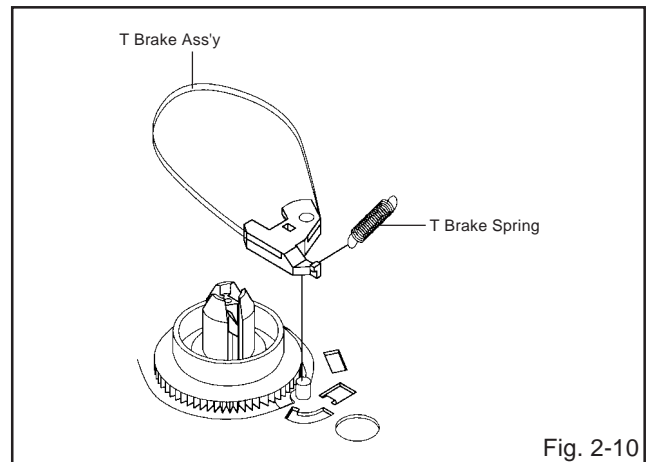

2-8: SENSOR COVER L2 (Refer to Fig. 2-8)

1. Unlock the support ① and remove the Sensor Cover L2.

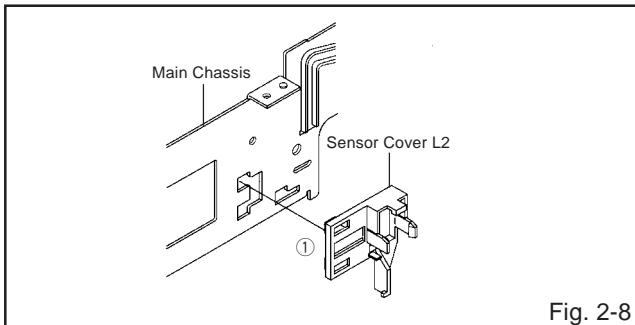

DISASSEMBLY INSTRUCTIONS

2-11: S REEL/T REEL (Refer to Fig. 2-11)

1. Remove the S Reel and T Reel.
2. Remove the 2 Polyslider Washers ①.

NOTE

1. Take care not to damage the gears of the S Reel and T Reel.
2. The Polyslider Washer may be remained on the back of the reel.
3. Take care not to damage the shaft.
4. Do not touch the section "A" of S Reel and T Reel. (Use gloves.) (Refer to Fig. 2-11) Do not adhere the stains on it.
5. When you install the reel, clean the shaft and oil it (FL OIL #6115). (If you do not oil, noise may be heard in FF/REW mode.)
6. After installing the reel, adjust the height of the reel. (Refer to MECHANICAL ADJUSTMENT)

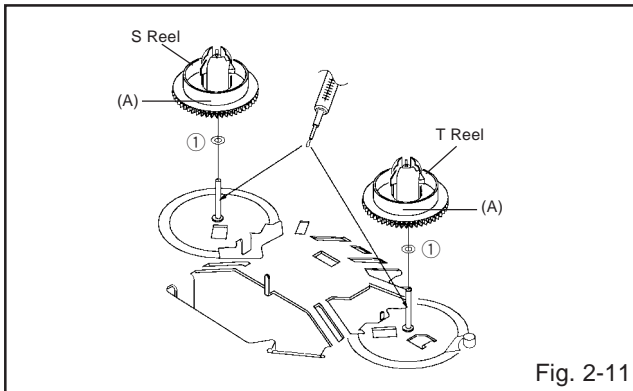
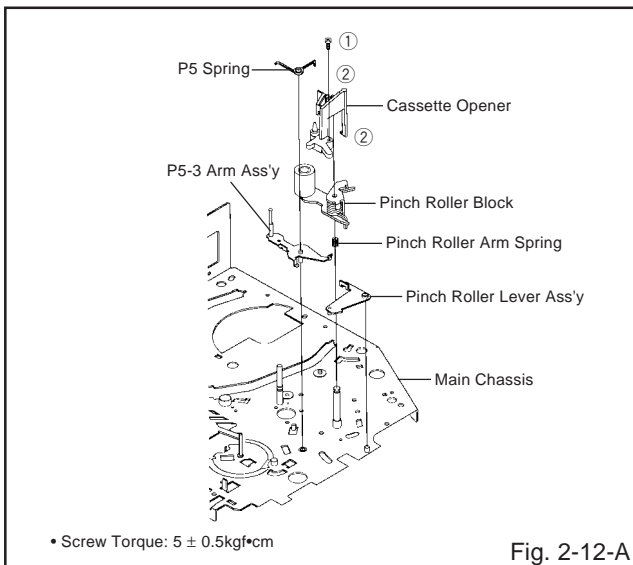

Fig. 2-11

2-12: PINCH ROLLER BLOCK/P5-3 ARM ASS'Y (Refer to Fig. 2-12-A)

1. Remove the P5 Spring.
2. Remove the screw ①.
3. Unlock the 2 supports ② and remove the Cassette Opener.
4. Remove the Pinch Roller Block, Pinch Roller Arm Spring, Pinch Roller Lever Ass'y and P5-3 Arm Ass'y.



• Screw Torque: $5 \pm 0.5\text{kg}\cdot\text{cm}$

Fig. 2-12-A

NOTE

1. Do not touch the Pinch Roller. (Use gloves.)
2. When you install the Pinch Roller Block, install as shown in the circle of Fig. 2-12-B. (Refer to Fig. 2-12-B)

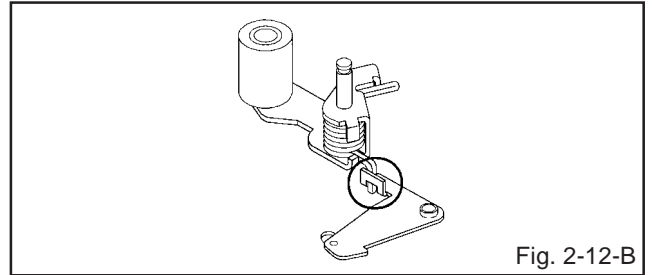

Fig. 2-12-B

2-13: A/C HEAD (Refer to Fig. 2-13-A)

1. Remove the screw ①.
2. Remove the A/C Head Base.
3. Remove the 3 screws ②.
4. Remove the A/C Head and A/C Head Spring.

NOTE

1. Do not touch the A/C Head. (Use gloves.)
2. When you install the A/C Head Spring, install as shown in Fig. 2-13-B. (Refer to Fig. 2-13-B)
3. When you install the A/C Head, tighten the screw (1) first, then tighten the screw (2), finally tighten the screw (3).

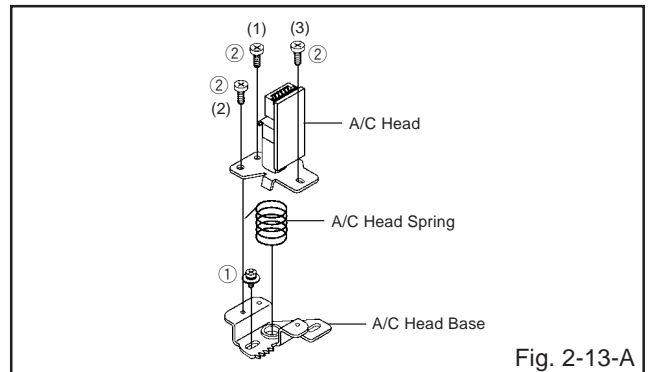

Fig. 2-13-A

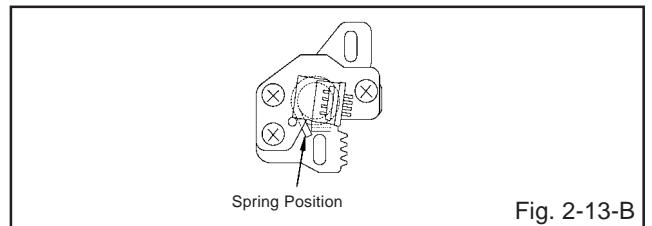
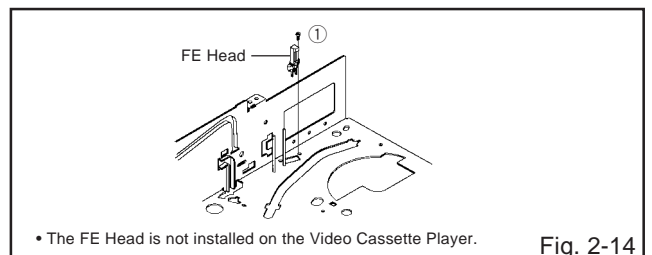

Fig. 2-13-B

2-14: FE HEAD (RECORDER ONLY) (Refer to Fig. 2-14)

1. Remove the screw ①.
2. Remove the FE Head.



• The FE Head is not installed on the Video Cassette Player.

Fig. 2-14

DISASSEMBLY INSTRUCTIONS

2-15: AHC ASS'Y/CYLINDER UNIT ASS'Y (Refer to Fig. 2-15)

1. Unlock the support ① and remove the AHC Ass'y.
2. Remove the 3 screws ②.
3. Remove the Cylinder Unit Ass'y.

NOTE

When you install the Cylinder Unit Ass'y, tighten the screws from (1) to (3) in order while pulling the Ass'y toward the left front direction.

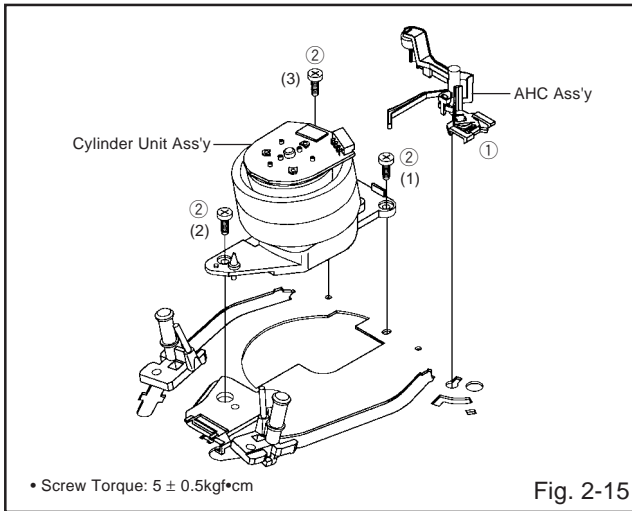

2-16: CAPSTAN DD UNIT (Refer to Fig. 2-16)

1. Remove the Capstan Belt.
2. Remove the 3 screws ①.
3. Remove the Capstan DD Unit.

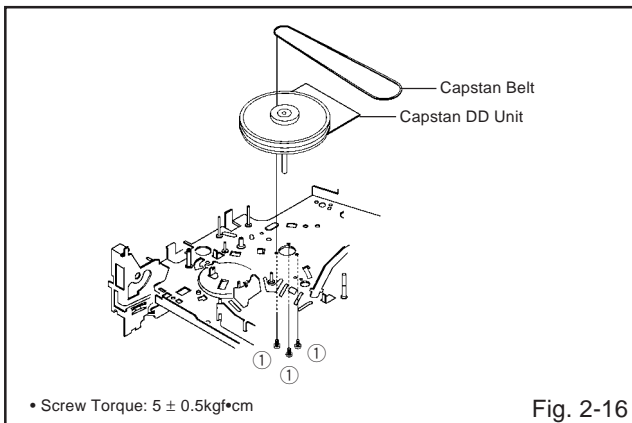

2-17: MIDDLE GEAR/MAIN CAM (Refer to Fig. 2-17-A)

1. Remove the Polyslider Washer ①, then remove the Middle Gear.
2. Remove the E-Ring, then remove the Main Cam, P5 Cam and Pinch Roller Cam.
3. Remove the Polyslider Washer ②, then remove the Joint Gear.

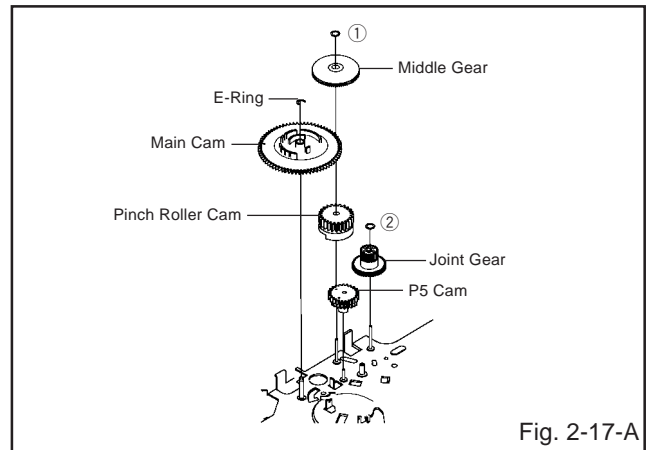

NOTE

When you install the Pinch Roller Cam, P5 Cam and Main Cam, align each marker. (Refer to Fig. 2-17-B)

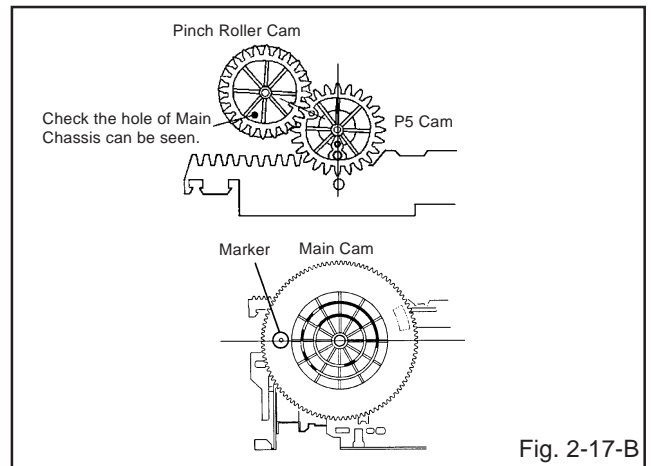

2-18: CLUTCH ASS'Y (Refer to Fig. 2-18)

1. Remove the Polyslider Washer ①.
2. Remove the Clutch Ass'y, Ring Spring and Coupling Gear.
3. Unlock the 2 supports ② and remove the Clutch Lever.

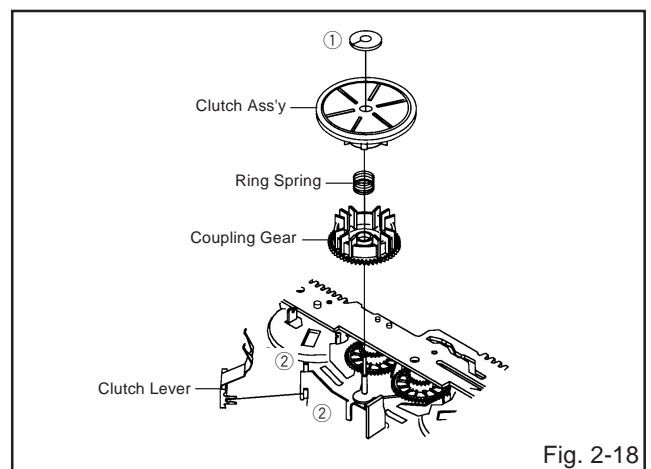

DISASSEMBLY INSTRUCTIONS

2-19: LOADING GEAR S/T ASS'Y (Refer to Fig. 2-19-A)

1. Remove the E-Ring ① and remove the Main Loading Gear.
2. Remove the Capstan Brake Spring.
3. Slide the Main Rod and remove the Capstan Brake Ass'y.
4. Remove the Main Rod, Tension Lever, Clutch Actuator, Idler Arm Ass'y.
5. Remove the screw ② and washer ③.
6. Remove the LED Reflector.
7. Remove the Loading Arm S Ass'y and Loading Arm T Ass'y.
8. Remove the Loading Gear S and Loading Gear T.
9. Remove the Loading Gear Spring.

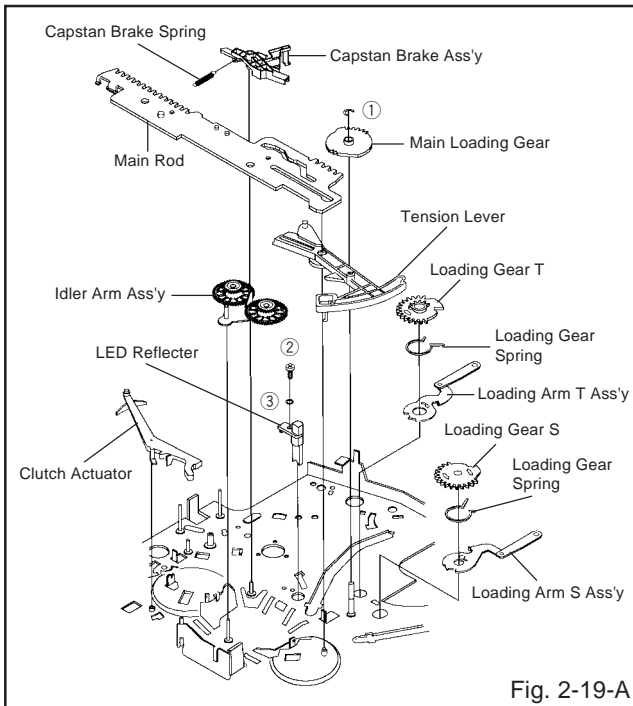

Fig. 2-19-A

NOTES

1. When you install the Loading Arm S Ass'y, Loading Arm T Ass'y and Main Loading Gear, align each marker. (Refer to Fig. 2-19-B)

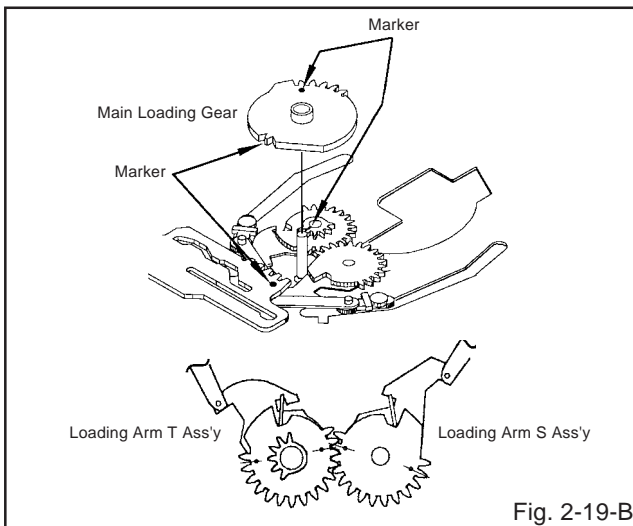

Fig. 2-19-B

2. When you install the Clutch Actuator, install as shown in the circle of Fig. 2-19-C. (Refer to Fig. 2-19-C)

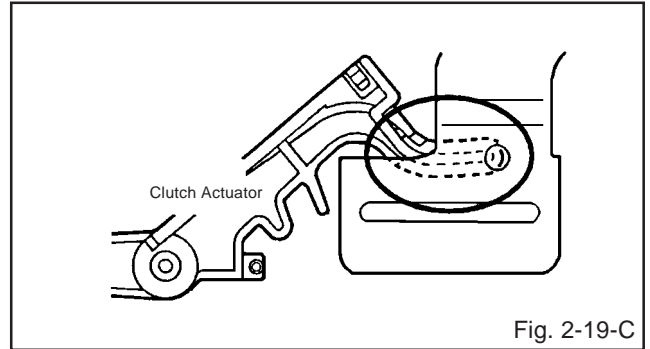

Fig. 2-19-C

2-20: INCLINED S/T ASS'Y (Refer to Fig. 2-20)

1. Unlock the support ① and remove the P4 Cover.
2. Unlock the support ② and remove the Loading Gear Holder.
3. Remove the Inclined S.
4. Remove the Inclined T.
5. Remove the 2 screws ③, then remove the Guide Roller and O-Ring.

NOTE

Do not touch the roller of Guide Roller.

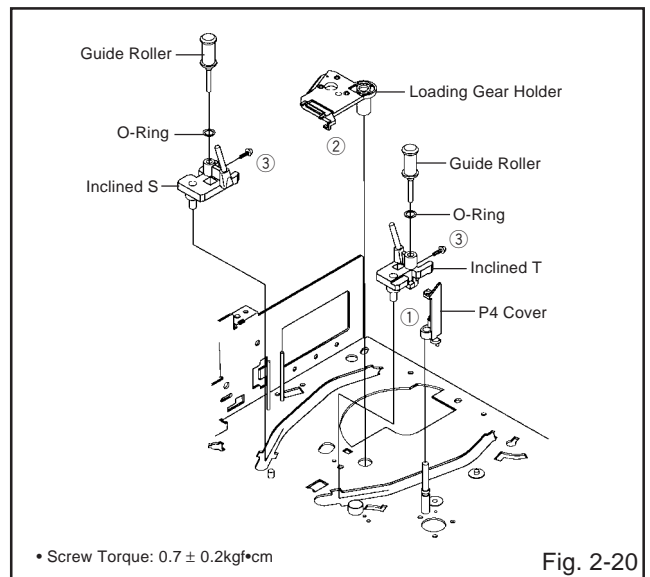

Fig. 2-20

KEY TO ABBREVIATIONS

A	A/C	: Audio/Control	H.SW	: Head Switch	
	ACC	: Automatic Color Control	Hz	: Hertz	
	AE	: Audio Erase	I	IC	: Integrated Circuit
	AFC	: Automatic Frequency Control		IF	: Intermediate Frequency
	AFT	: Automatic Fine Tuning		IND	: Indicator
	AFT DET	: Automatic Fine Tuning Detect		INV	: Inverter
	AGC	: Automatic Gain Control	K	KIL	: Killer
	AMP	: Amplifier	L	L	: Left
	ANT	: Antenna		LED	: Light Emitting Diode
	A.PB	: Audio Playback		LIMIT AMP	: Limiter Amplifier
	APC	: Automatic Phase Control		LM, LDM	: Loading Motor
	ASS'Y	: Assembly		LP	: Long Play
	AT	: All Time		L.P.F	: Low Pass Filter
	AUTO	: Automatic		LUMI.	: Luminance
	A/V	: Audio/Video	M	M	: Motor
B	BGP	: Burst Gate Pulse		MAX	: Maximum
	BOT	: Beginning of Tape		MINI	: Minimum
	BPF	: Bandpass Filter		MIX	: Mixer, mixing
	BRAKE SOL	: Brake Solenoid		MM	: Monostable Multivibrator
	BUFF	: Buffer		MOD	: Modulator, Modulation
	B/W	: Black and White		MPX	: Multiplexer, Multiplex
C	C	: Capacitance, Collector		MS SW	: Mecha State Switch
	CASE	: Cassette	N	NC	: Non Connection
	CAP	: Capstan		NR	: Noise Reduction
	CARR	: Carrier	O	OSC	: Oscillator
	CH	: Channel		OPE	: Operation
	CLK	: Clock	P	PB	: Playback
	CLOCK (SY-SE)	: Clock (Syscon to Servo)		PB CTL	: Playback Control
	COMB	: Combination, Comb Filter		PB-C	: Playback-Chrominance
	CONV	: Converter		PB-Y	: Playback-Luminance
	CPM	: Capstan Motor		PCB	: Printed Circuit Board
	CTL	: Control		P. CON	: Power Control
	CYL	: Cylinder		PD	: Phase Detector
	CYL-M	: Cylinder-Motor		PG	: Pulse Generator
	CYL SENS	: Cylinder-Sensor		P-P	: Peak-to Peak
D	DATA (SY-CE)	: Data (Syscon to Servo)	R	R	: Right
	dB	: Decibel		REC	: Recording
	DC	: Direct Current		REC-C	: Recording-Chrominance
	DD Unit	: Direct Drive Motor Unit		REC-Y	: Recording-Luminance
	DEMODO	: Demodulator		REEL BRK	: Reel Brake
	DET	: Detector		REEL S	: Reel Sensor
	DEV	: Deviation		REF	: Reference
E	E	: Emitter		REG	: Regulated, Regulator
	EF	: Emitter Follower		REW	: Rewind
	EMPH	: Emphasis		REV, RVS	: Reverse
	ENC	: Encoder		RF	: Radio Frequency
	ENV	: Envelope		RMC	: Remote Control
	EOT	: End of Tape		RY	: Relay
	EQ	: Equalizer	S	S. CLK	: Serial Clock
	EXT	: External		S. COM	: Sensor Common
F	F	: Fuse		S. DATA	: Serial Data
	FBC	: Feed Back Clamp		SEG	: Segment
	FE	: Full Erase		SEL	: Select, Selector
	FF	: Fast Forward, Flipflop		SENS	: Sensor
	FG	: Frequency Generator		SER	: Search Mode
	FL SW	: Front Loading Switch		SI	: Serial Input
	FM	: Frequency Modulation		SIF	: Sound Intermediate Frequency
	FSC	: Frequency Sub Carrier		SO	: Serial Output
	FWD	: Forward		SOL	: Solenoid
G	GEN	: Generator		SP	: Standard Play
	GND	: Ground		STB	: Serial Strobe
H	H.P.F	: High Pass Filter		SW	: Switch

KEY TO ABBREVIATIONS

S	SYNC	:	Synchronization
	SYNC SEP	:	Sync Separator, Separation
T	TR	:	Transistor
	TRAC	:	Tracking
	TRICK PB	:	Trick Playback
	TP	:	Test Point
U	UNREG	:	Unregulated
V	V	:	Volt
	VCO	:	Voltage Controlled Oscillator
	VIF	:	Video Intermediate Frequency
	VP	:	Vertical Pulse, Voltage Display
	V.PB	:	Video Playback
	VR	:	Variable Resistor
	V.REC	:	Video Recording
	VSF	:	Visual Search Fast Forward
	VSR	:	Visual Search Rewind
	VSS	:	Voltage Super Source
	V-SYNC	:	Vertical-Synchronization
	VT	:	Voltage Tuning
X	X'TAL	:	Crystal
Y	Y/C	:	Luminance/Chrominance

SERVICE MODE LIST

This unit provided with the following SERVICE MODES so you can repair, examine and adjust easily.

Method	Operations
Press both PLAY button and CH UP button on the set for more than 2 seconds.	Initialization of the factory. NOTE: Do not use this for the normal servicing.
While pressing the CH UP key on the set, press the FF key on the set for more than 2 seconds.	PLAY/REC total hours are displayed on the TV Monitor. Refer to the "PREVENTIVE CHECKS AND SERVICE INTERVALS" (CONFIRMATION OF USING HOURS). Can be checked of the INITIAL DATA of MEMORY IC. Refer to the "NOTE FOR THE REPLACING OF MEMORY IC".
Press the ATR button on the remote control for more than 2 seconds during PLAY.	Adjusting of the Tracking to the center position. Refer to the "MECHANICAL ADJUSTMENT" (GUIDE ROLLER) and "ELECTRICAL ADJUSTMENT" (PG SHIFTER).
Make the short circuit between the test point of SERVICE and the GND.	The EOT/BOT/Reel sensor do not work at this moment. Refer to the "PREPARATION FOR SERVICING"

PREVENTIVE CHECKS AND SERVICE INTERVALS

The following standard table depends on environmental conditions and usage. Unless maintenance is properly carried out, the following service intervals may be quite shortened as harmful effects may be had on other parts. Also, long term storage or misuse may cause transformation and aging of rubber parts.

Time Parts Name	500 hours	1,000 hours	1,500 hours	2,000 hours	3,000 hours	Notes
Audio Control Head	■	■	■	■	■	Clean those parts in contact with the tape.
Full Erase Head (Recorder only)	■	■	■	■	■	
Capstan Belt			■	■	●	Clean the rubber, and parts which the rubber touches.
Pinch Roller	■	■	■	■	■ ●	
Capstan DD Unit					●	
Loading Motor					●	
Tension Band					●	
Capstan Shaft	■	■	■	■	■	
Tape Running Guide Post	■	■	■	■	■	Replace when rolling becomes abnormal.
Cylinder Unit	■	■	■	■	●	Clean the Head

- : Clean
- : Replace

CONFIRMATION OF USING HOURS

PLAY/REC total hours can be checked on the TV Monitor.
Total hours are displayed in 16 system of notation.

1. Connect the set to TV Monitor.
2. Turn on the POWER.
3. While pressing the CH UP button on the set, press the FF button on the set for more than 2 seconds.
4. Adjust the ADDRESS to "7D" by SET +/- button and read the DATA.
(This DATA becomes the thousands digit and hundreds digit value of the following formula.)
5. Adjust the ADDRESS to "7E" by SET +/- button and read the DATA.
(This DATA becomes the tens digit and ones digit value of the following formula.)
6. After the confirmation of using hours, turn off the power.

INIT 01 EB

┌──┬──┐
ADDRESS DATA

(16 x 16 x 16 x thousands digit value) + (16 x 16 x hundreds digit value) + (16 x tens digit value) + (ones digit value)

PREVENTIVE CHECKS AND SERVICE INTERVALS

CLEANING

NOTE

After cleaning the heads with isopropyl alcohol, do not run a tape until the heads dry completely. If the heads are not completely dry and alcohol gets on the tape, damage may occur.

1. AUDIO CONTROL HEAD

Wrap a piece of chamois around your finger. Dip it in isopropyl alcohol and clean the audio control head by wiping it horizontally. Clean the full erase head in the same manner. **(Refer to the figure below.)**

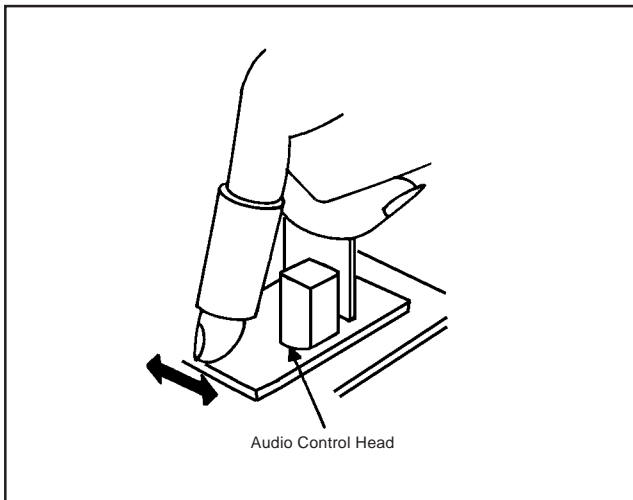

2. TAPE RUNNING SYSTEM

When cleaning the tape transport system, use the gauze moistened with isopropyl alcohol.

3. CYLINDER

Wrap a piece of chamois around your finger. Dip it in isopropyl alcohol. Hold it to the cylinder head softly. Turn the cylinder head counterclockwise to clean it (in the direction of the arrow). **(Refer to the figure below.)**

NOTE

Do not exert force against the cylinder head. Do not move the chamois upward or downward on the head. Use the chamois one by one.

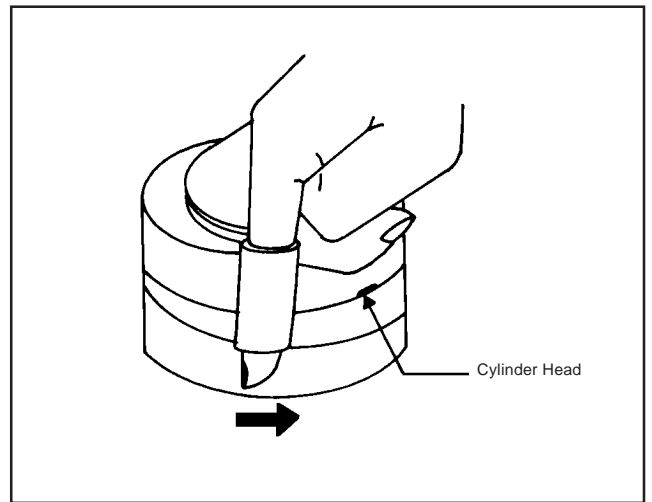

NOTE FOR THE REPLACING OF MEMORY IC

If a service repair is undertaken where it has been required to change the MEMORY IC, the following steps should be taken to ensure correct data settings while making reference to TABLE 1.

ADDRESS	INI	INI	INI	INI	INI	INI	INI	INI	INI	INI	INI	INI	INI	INI	INI	INI	INI	INI	INI
	00	01	02	03	04	05	06	07	08	09	0A	0B	0C	0D	0E	0F	10	11	12
DATA	0B	03	00	64	64	4A	0A	00	26	8F	53	0C	08	0C	00	8C	68	5C	53

Table 1

1. Connect the set to TV Monitor.
2. Turn on the POWER.
3. While pressing the CH UP key on the set, press the FF key on the set for more than 2 seconds.
4. ADDRESS and DATA will appear on TV Monitor as FIG 1.

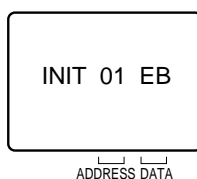
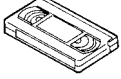

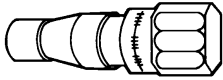
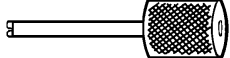
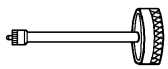
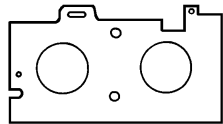
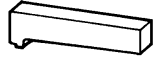
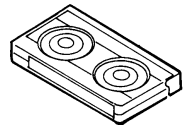
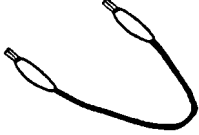
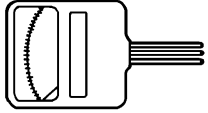

Fig. 1

5. ADDRESS is now selected and should "blink". Using the SET + or - keys on the remote, step through the ADDRESS until required ADDRESS to be changed is reached.
6. Press ENTER to select DATA. When DATA is selected, it will "blink".
7. Again, step through the DATA using SET + or - until required DATA value has been selected.
8. Pressing ENTER will take you back to ADDRESS for further selection if necessary.
9. Repeat steps 5 to 8 until all data has been checked.
10. When satisfied correct DATA has been entered, turn POWER off (return to STANDBY MODE) to finish DATA input. The unit will now have the correct DATA for the new MEMORY IC.

SERVICING FIXTURES AND TOOLS

<p>(For 2 heads model) VHS Alignment Tape JG001 (VN₂S-LI6³) JG001A (VN₂S-CO1³) JG001Q (VN₂S-LI6³H) JG001T (VN₂S-X6³)</p> 	<p>(For 4 heads model) VHS Alignment Tape JG001B (VN₁S-LI6³) JG001I (VN₁S-CO1³) JG001P (VN₁S-LI6³H) JG001S (VN₁S-X6³)</p> 	<p>JG002B Adapter JG002E Dial Torque Gauge (10~90gf•cm) JG002F (60~600gf•cm)</p> 	<p>JG005 Post Adjustment Screwdriver Part No. SV-TG0-030-000 (small)</p> 
<p>JG153 X Value Adjustment Screwdriver</p> 	<p>JG022 Master Plane</p> 	<p>JG024A Reel Disk Height Adjustment Jig</p> 	<p>JG100A Torque Tape (VHT-063)</p> 
<p>JG154 Cable</p> 	<p>Tentelometer</p> 		

Part No.	Remarks
JG001	Monoscope, 6KHz (For 2 heads model)
JG001A	Color Bar, 1KHz (For 2 heads model)
JG001Q	Hi-Fi Audio (For 2 heads Hi-Fi model)
JG001T	X Value Adjustment (For 2 heads model)
JG001B	Monoscope, 6KHz (For 4 heads model)
JG001I	Color Bar, 1KHz (For 4 heads model)
JG001P	Hi-Fi Audio (For 4 heads Hi-Fi model)
JG001S	X Value Adjustment (For 4 heads model)
JG002B	VSR Torque, Brake Torque (S Reel/T Reel Ass'y)
JG002E	Brake Torque (T Reel Ass'y)
JG002F	VSR Torque, Brake Torque (S Reel)
JG005	Guide Roller Adjustment
JG153	X Value Adjustment
JG022/JG024A	Reel Disk Height Adjustment
JG100A	Playback Torque, Back Tension Torque During Playback
JG154	Used to connect the test point of SERVICE and GROUND

PREPARATION FOR SERVICING

- Short circuit between **TP1001** and **Ground** with the cable JG154.
(Refer to MAJOR COMPONENTS LOCATION GUIDE)
The EOT, BOT and Reel Sensor do not work at this moment.
At that time, the STOP/EJECT button is available to insert and eject the Cassette Tape.

MECHANICAL ADJUSTMENTS

1. CONFIRMATION AND ADJUSTMENT

Read the following NOTES before starting work.

- Place an object which weighs between 450g~500g on the Cassette Tape to keep it steady when you want to make the tape run without the Cassette Holder. (Do not place an object which weighs over 500g.)
- When you activate the deck without the Cassette Holder, short circuit between **TP1001** and **GND**. (Refer to **ELECTRICAL ADJUSTMENT PARTS LOCATION GUIDE**) In this condition the BOT/EOT/Reel Sensor will not function.

1-1: CONFIRMATION AND ADJUSTMENT OF REEL DISK HEIGHT

1. Turn on the power and set to the STOP mode.
2. Set the master plane (**JG022**) and reel disk height adjustment jig (**JG024A**) on the mechanism framework, taking care not to scratch the drum, as shown in **Fig. 1-1-A**.
3. Confirm that "A" of the reel disk is lower than "B" of the reel disk height adjustment jig (**JG024A**), and is higher than "C". If it is not enough height, adjust to $10(+0.2, -0)$ mm with the height adjustment washer.
4. Adjust the other reel in the same way.

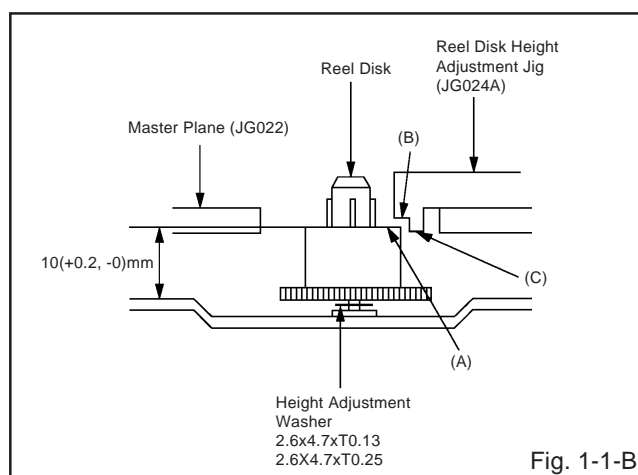
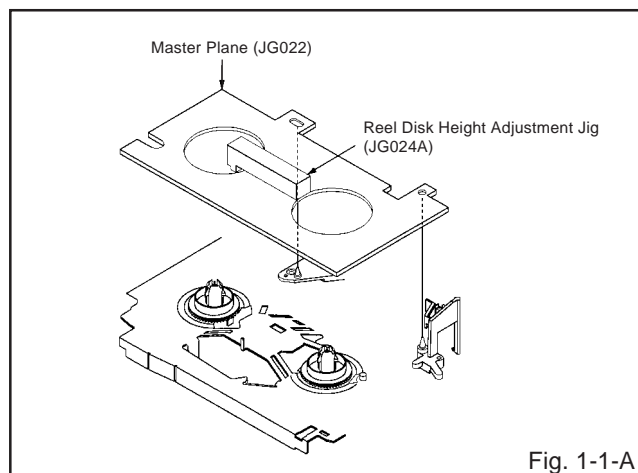

1-2: CONFIRMATION AND ADJUSTMENT OF TENSION POST POSITION

1. Set to the PLAY mode.
2. Adjust the Tension Adjust until the edge of the Tension Arm is positioning within 0.5mm range from the standard line center of Main Chassis. After this adjustment, confirm that the cut position is located in "A" area as shown in **Fig. 1-2-B**. If it is located in "B" area, adjust again.
3. While turning the S Reel clockwise, confirm that the edge of the Tension Arm is located in the position described above.

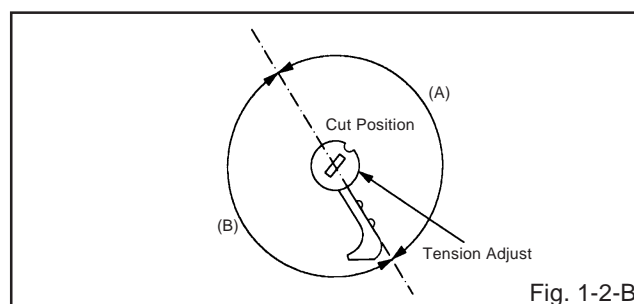
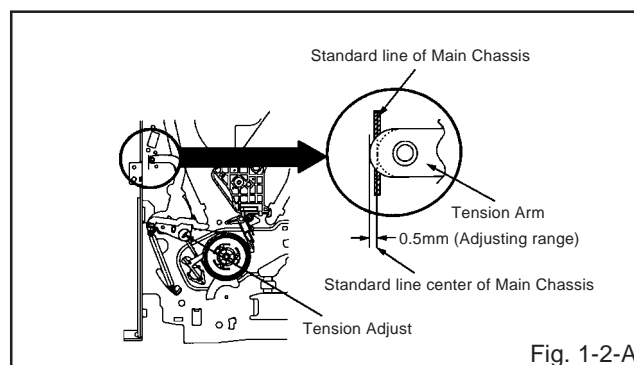

1-3: CONFIRMATION OF PLAYBACK TORQUE AND BACK TENSION TORQUE DURING PLAYBACK

1. Load a video tape (T-120) recorded in standard speed mode. Set the unit to the PLAY mode.
2. Install the tentelometer as shown in **Fig. 1-3**. Confirm that the meter indicates 20 ± 2 gf in the beginning of playback.

• USING A CASSETTE TYPE TORQUE TAPE (**JG100A**)

1. After confirmation and adjustment of Tension Post position (Refer to item 1-2), load the cassette type torque tape (**JG100A**) and set to the PLAY mode.
2. Confirm that the right meter of the torque tape indicates $60 \sim 110$ gf•cm during playback in SP mode.
3. Confirm that the left meter of the torque tape indicates $25 \sim 40$ gf•cm during playback in SP mode.

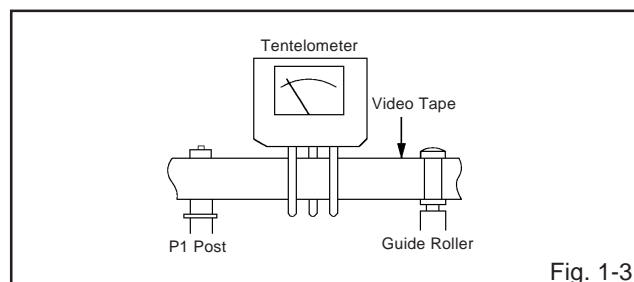

MECHANICAL ADJUSTMENTS

1-4: CONFIRMATION OF VSR TORQUE

1. Operate within 4~5 seconds after the reel disk begins to turn.
2. Install the Torque Gauge (JG002F) and Adapter (JG002B) on the S Reel. Set to the Rewind mode. (Refer to Fig.1-4)
3. Then, confirm that it indicates 120~180gf•cm.

NOTE

Install the Torque Gauge on the reel disk firmly. Press the REW button to turn the reel disk.

1-5: CONFIRMATION OF REEL BRAKE TORQUE

(S Reel Brake) (Refer to Fig. 1-4)

1. Set to the STOP mode.
2. Move the Idler Ass'y from the S Reel.
3. Install the Torque Gauge (JG002F) and Adapter (JG002B) on the S Reel. Turn the Torque Gauge (JG002F) clockwise.
4. Then, confirm that it indicates 60~100gf•cm.

(T Reel Brake) (Refer to Fig. 1-4)

1. Set to the STOP mode.
2. Move the Idler Ass'y from the T Reel.
3. Install the Torque Gauge (JG002E) and Adapter (JG002B) on the T reel. Turn the Torque Gauge (JG002E) counterclockwise.
4. Then, confirm that it indicates 45~70gf•cm.

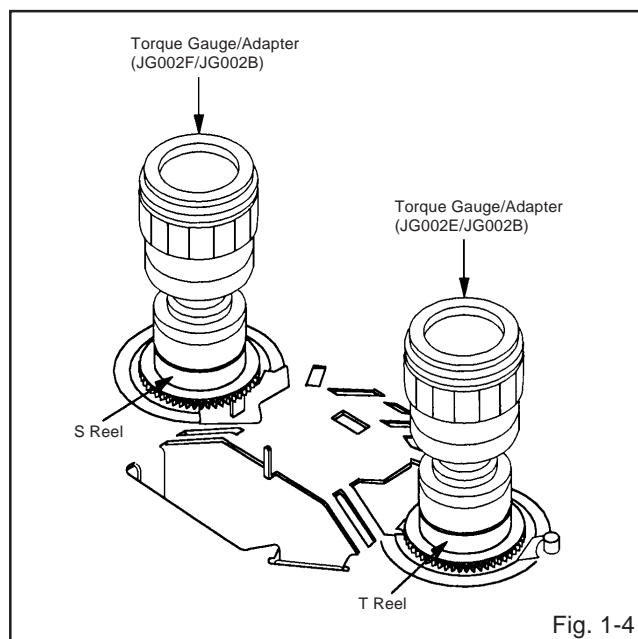

NOTE

If the torque is out of the range, replace the following parts.

Check item	Replacement Part
1-4	Idler Ass'y/Clutch Ass'y
1-5	T Brake Spring/Tension Spring

2. CONFIRMATION AND ADJUSTMENT OF TAPE RUNNING MECHANISM

Tape Running Mechanism is adjusted precisely at the factory. Adjustment is not necessary as usual. When you replace the parts of the tape running mechanism because of long term usage or failure, the confirmation and adjustment are necessary.

2-1: GUIDE ROLLER

1. Playback the VHS Alignment Tape (JG001 or JG001B). (Refer to SERVICING FIXTURE AND TOOLS)
2. Connect CH-1 of the oscilloscope to TP4001 (Envelope) and CH-2 to TP1002 (SW Pulse).
3. Press and hold the Tracking-Auto button on the remote control more than 2 seconds to set tracking to center.
4. Trigger with SW Pulse and observe the envelope. (Refer to Fig. 2-1-A)
5. When observing the envelope, adjust the Adjusting Driver (JG005) slightly until the envelope will be flat. Even if you press the Tracking Button, adjust so that flatness is not moved so much.
6. Adjust so that the A : B ratio is better than 3 : 2 as shown in Fig. 2-1-B, even if you press the Tracking Button to move the envelope (The envelope waveform will begin to decrease when you press the Tracking Button).
7. Adjust the PG shifter during playback. (Refer to the ELECTRICAL ADJUSTMENTS)

NOTE

After adjustment, confirm and adjust A/C head. (Refer to item 2-2)

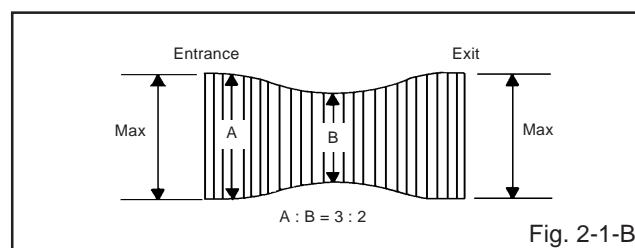
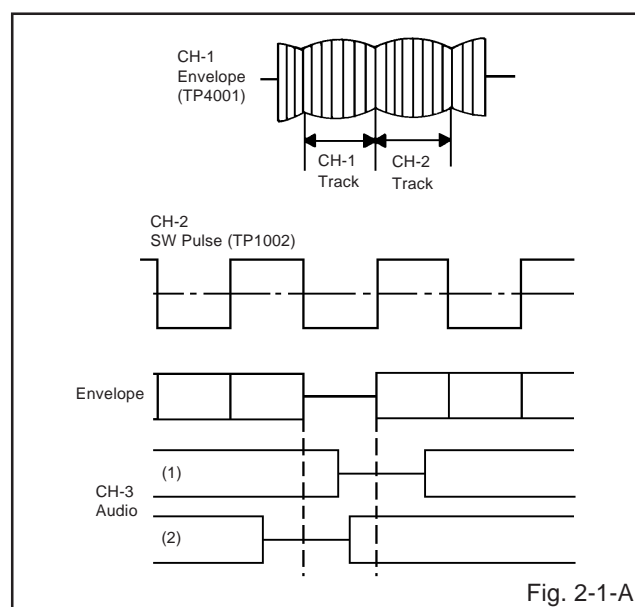

MECHANICAL ADJUSTMENTS

2-2: CONFIRMATION AND ADJUSTMENT OF AUDIO/CONTROL HEAD

When the Tape Running Mechanism does not work well, adjust the following items.

1. Playback the VHS Alignment Tape (**JG001 or JG001B**).
(Refer to **SERVICING FIXTURE AND TOOLS**)
2. Confirm that the reflected picture of stamp mark is appeared on the tape prior to P4 Post as shown in **Fig. 2-2-A**.
 - a) When the reflected picture is distorted, turn the screw ① clockwise until the distortion is disappeared.
 - b) When the reflected picture is not distorted, turn the screw ① counterclockwise until little distortion is appeared, then adjust the a).
3. Turn the screw ② to set the audio level to maximum.
4. Confirm that the bottom of the Audio/ Control Head and the bottom of the tape is shown in **Fig. 2-2-C**.
 - c) When the height is not correct, turn the screw ③ to adjust the height. Then, adjust the 1~3 again.

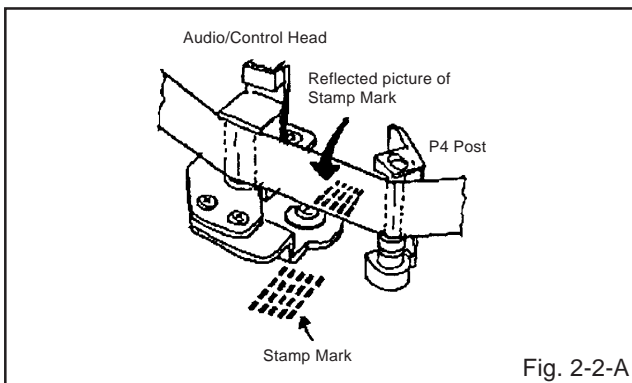

Fig. 2-2-A

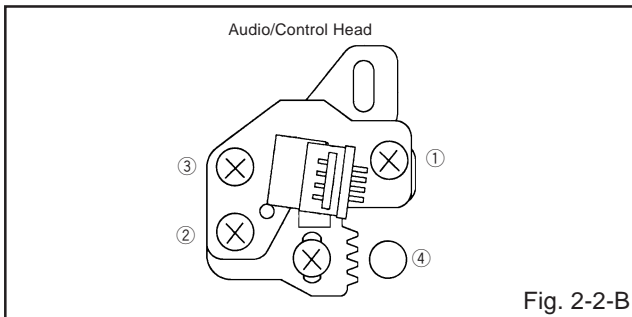

Fig. 2-2-B

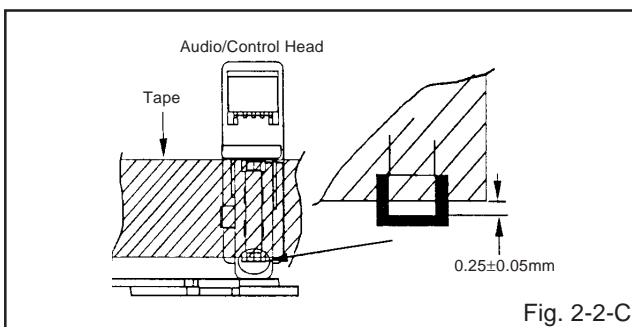

Fig. 2-2-C

2-3: TAPE RUNNING ADJUSTMENT (X VALUE ADJUSTMENT)

1. Confirm and adjust the height of the Reel Disk.
(Refer to **item 1-1**)
2. Confirm and adjust the position of the Tension Post.
(Refer to **item 1-2**)
3. Adjust the Guide Roller. (Refer to **item 2-1**)
4. Confirm and adjust the Audio/Control Head.
(Refer to **item 2-2**)
5. Connect CH-1 of the oscilloscope to **TP4001**, CH-2 to **TP1002** and CH-3 to **HOT side of Audio Out Jack**.
6. Playback the VHS Alignment Tape (**JG001S or JG001T**).
(Refer to **SERVICING FIXTURE AND TOOLS**)
7. Press and hold the Tracking-Auto button on the remote control more than 2 seconds to set tracking to center.
8. Set the X Value adjustment driver (**JG153**) to the ④ of **Fig. 2-2-B**. Adjust X value so that the envelope waveform output becomes maximum. Check if the relation between Audio and Envelope waveform becomes (1) or (2) of **Fig. 2-1-A**.

2-4: CONFIRM HI-FI AUDIO (Hi-Fi model only)

1. Connect CH-1 of the oscilloscope to **TP4001**, CH-2 to **TP1002** and CH-3 to the **Hi-Fi Audio Out Jack**.
2. Playback the VHS Alignment Tape (**JG001P or JG001Q**).
(Refer to **SERVICING FIXTURE AND TOOLS**)
3. Press and hold the Tracking-Auto button on the remote control more than 2 seconds to set tracking to center.
4. Press the Tracking Up button and count number of steps which the audio output is changed from Hi-Fi (10KHz) to MONO (6KHz).
5. Press the Tracking Down button and count number of steps which the audio output is changed from Hi-Fi (10KHz) to MONO (6KHz).
6. Confirm that the difference between these counted steps number in the above items are within 2 steps. If the difference are more than 3 steps, do Tape Running Adjustment again. (Refer to **item 2-3**)

MECHANICAL ADJUSTMENTS

3. MECHANISM ADJUSTMENT PARTS LOCATION GUIDE

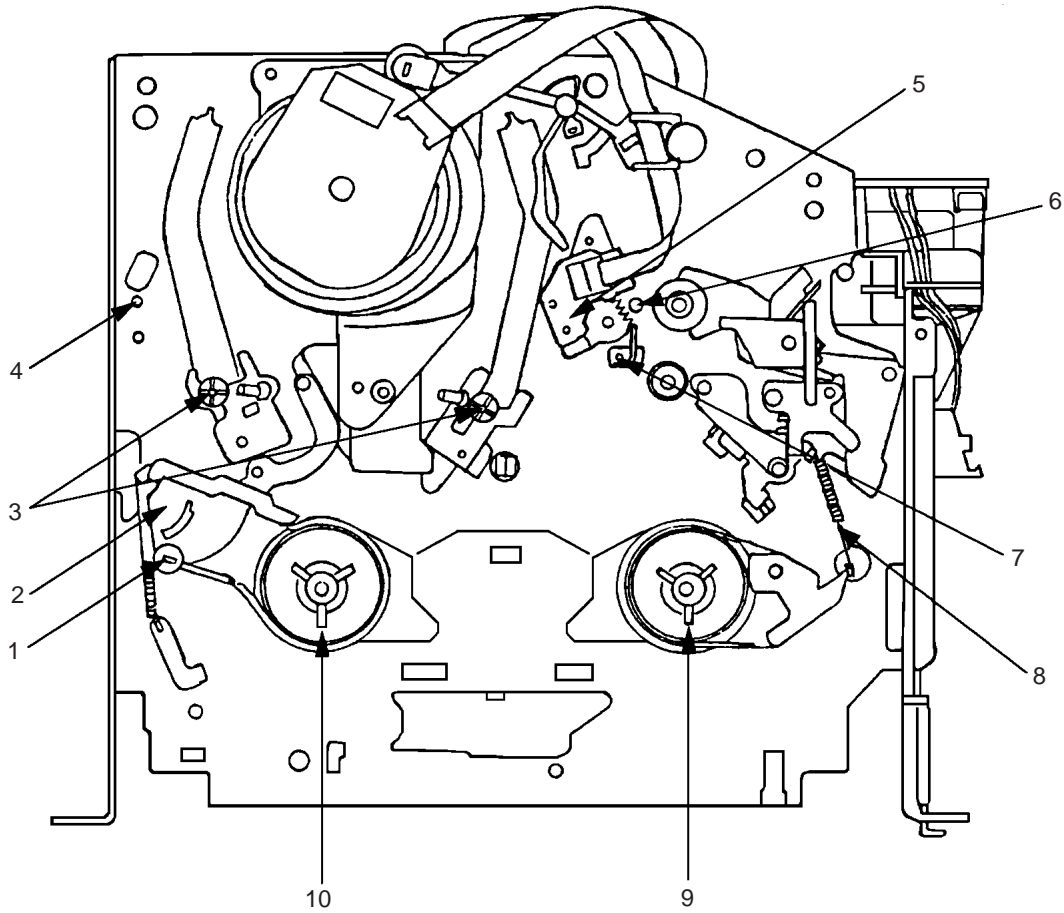

- | | |
|-----------------------|-----------------------------------|
| 1. Tension Adjust | 6. X value adjustment driver hole |
| 2. Tension Arm | 7. P4 Post |
| 3. Guide Roller | 8. T Brake Spring |
| 4. P1 Post | 9. T Reel |
| 5. Audio/Control Head | 10. S Reel |

ELECTRICAL ADJUSTMENTS

Read and perform this adjustment when repairing the circuits or replacing electrical parts or PCB assemblies.

1. BASIC ADJUSTMENT

CAUTION

When replacing IC's or transistors, use only specified silicon grease (**YG6260M**).
(To prevent the damage to IC's and transistors.)

1-1: PG SHIFTER

CONDITIONS

MODE-PLAYBACK
Input Signal-Alignment Tape (**JG001A**)

INSTRUCTIONS

1. Connect CH-1 on the oscilloscope to **TP1002** and CH-2 to **TP4201**.
2. Playback the alignment tape. (**JG001A**)
3. Press and hold the Tracking-Auto button on the remote control more than 2 seconds to set tracking to center.
4. Adjust the **VR1001** until the waveform of the oscilloscope measures $6.5 \pm 0.5(H)$ at both leading and trailing edges. (**Refer to Fig. 1-1-A, B**)

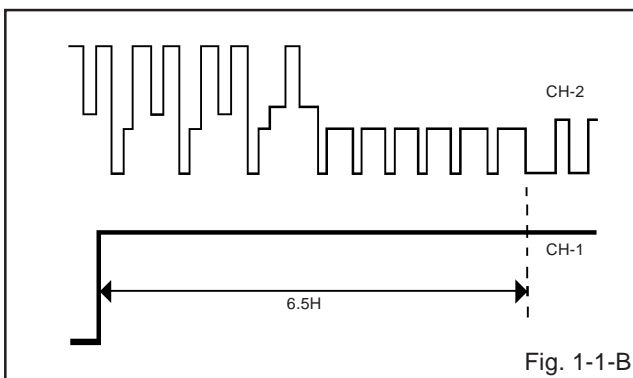
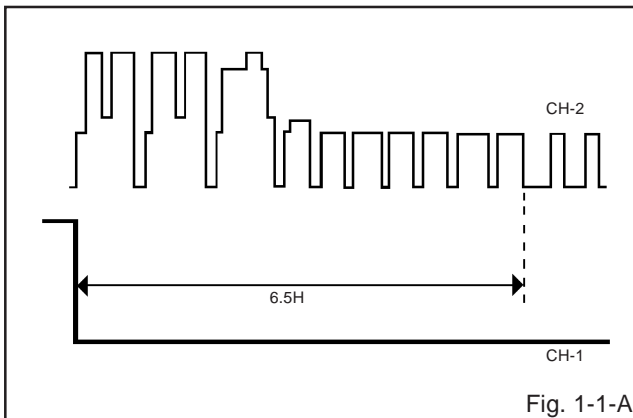

ELECTRICAL ADJUSTMENTS

2. ELECTRICAL ADJUSTMENT PARTS LOCATION GUIDE

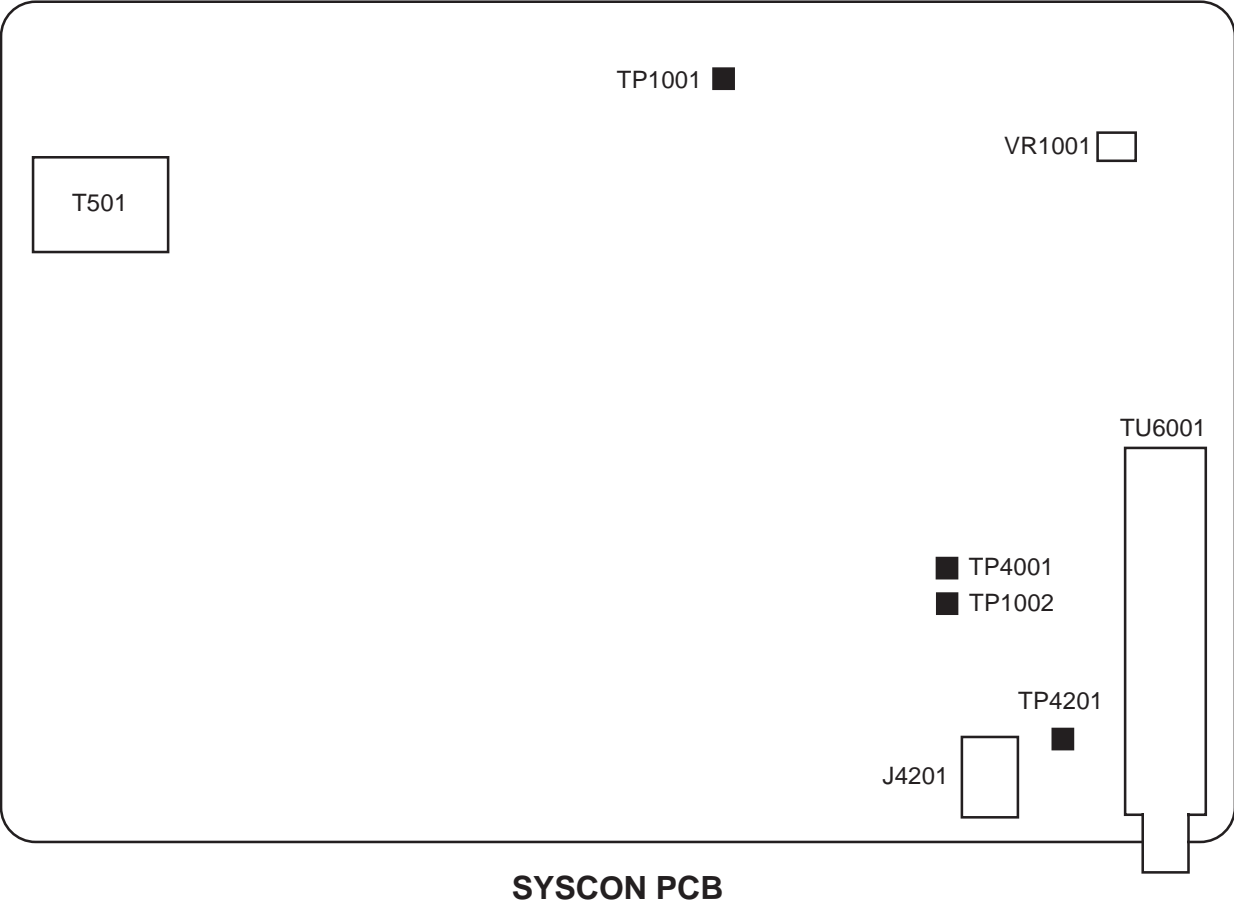

TUNER BLOCK DIAGRAM

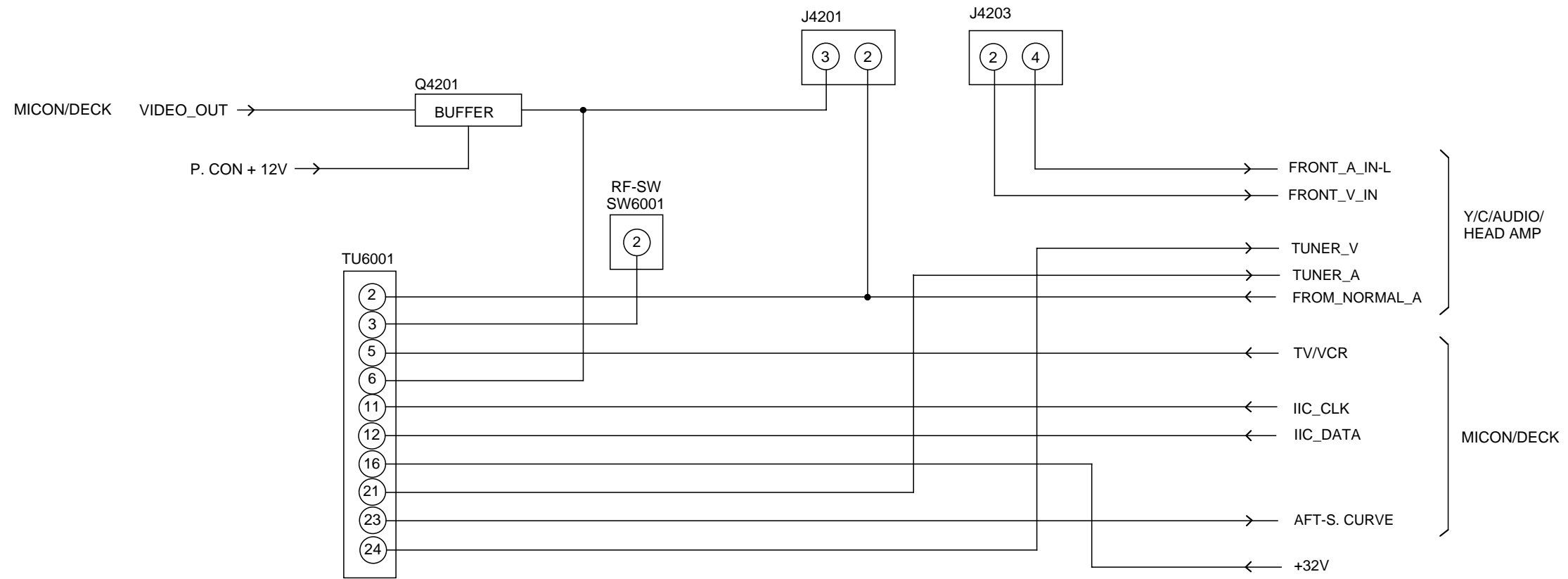

MICON/DECK BLOCK DIAGRAM

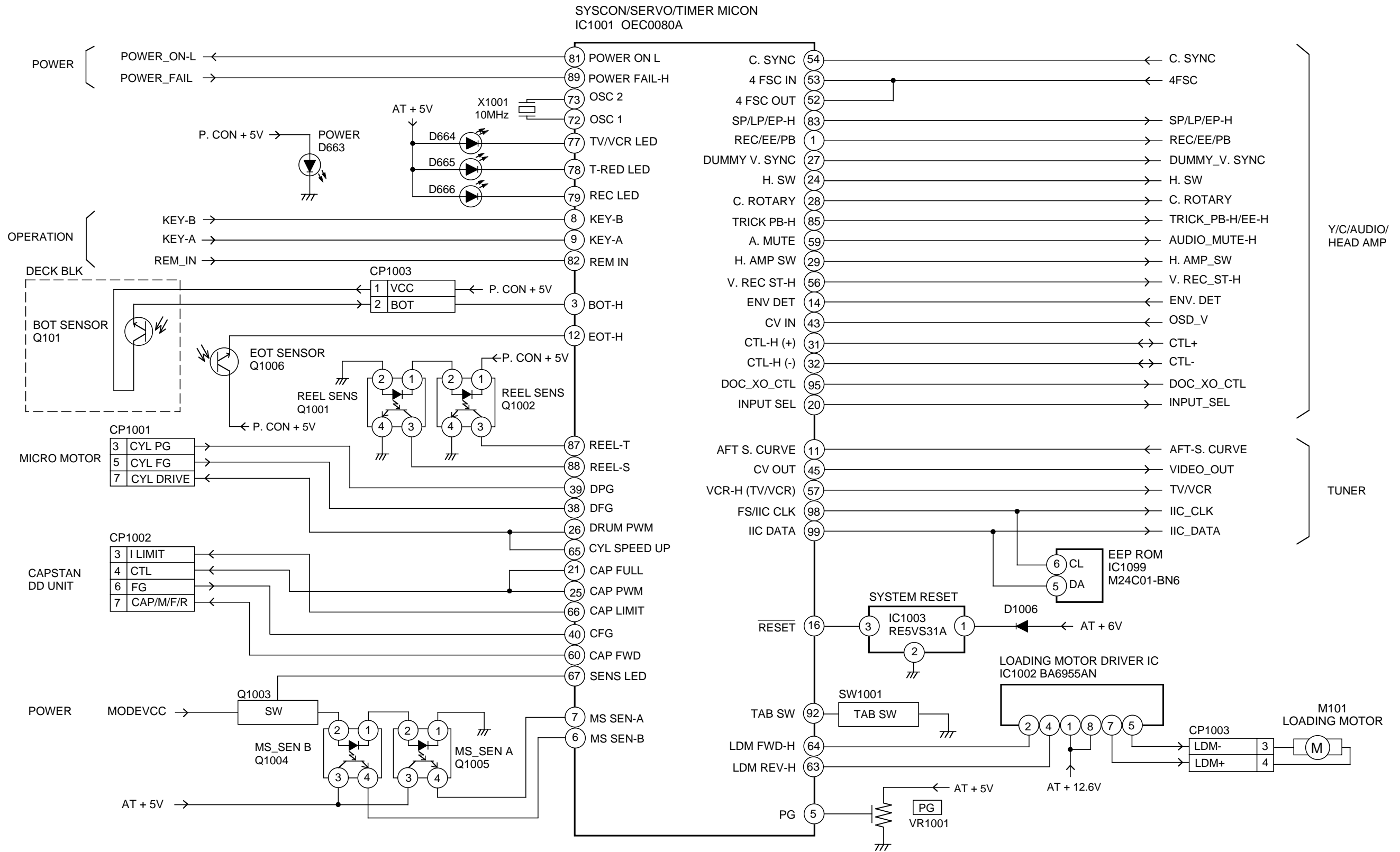

OPERATION BLOCK DIAGRAM

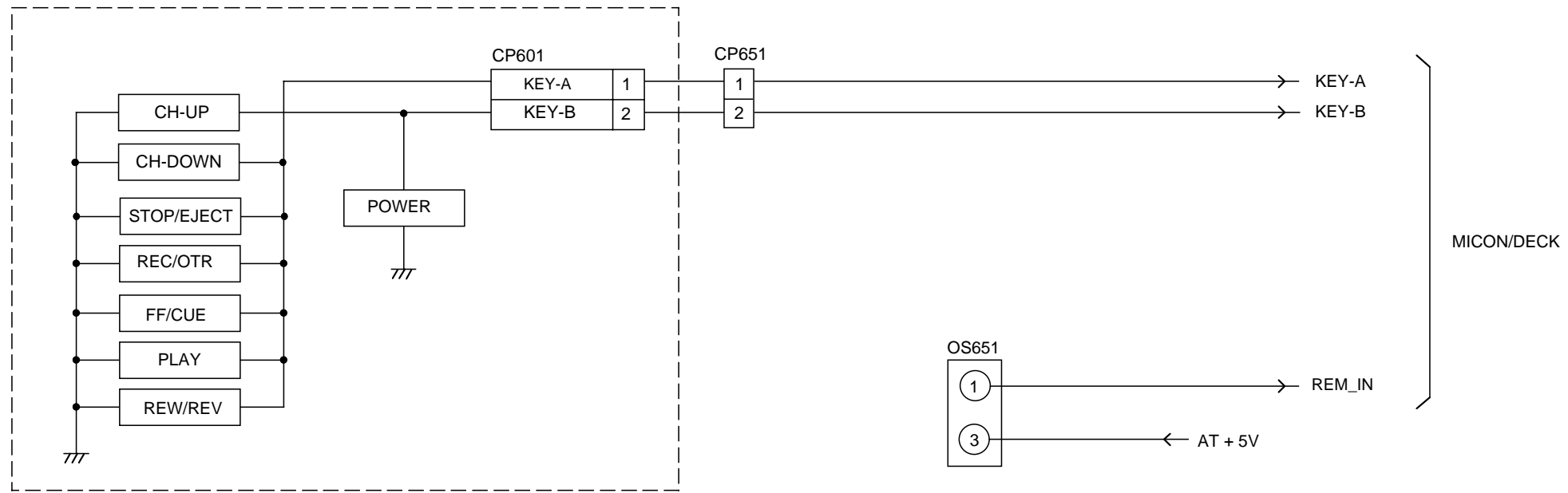

POWER BLOCK DIAGRAM

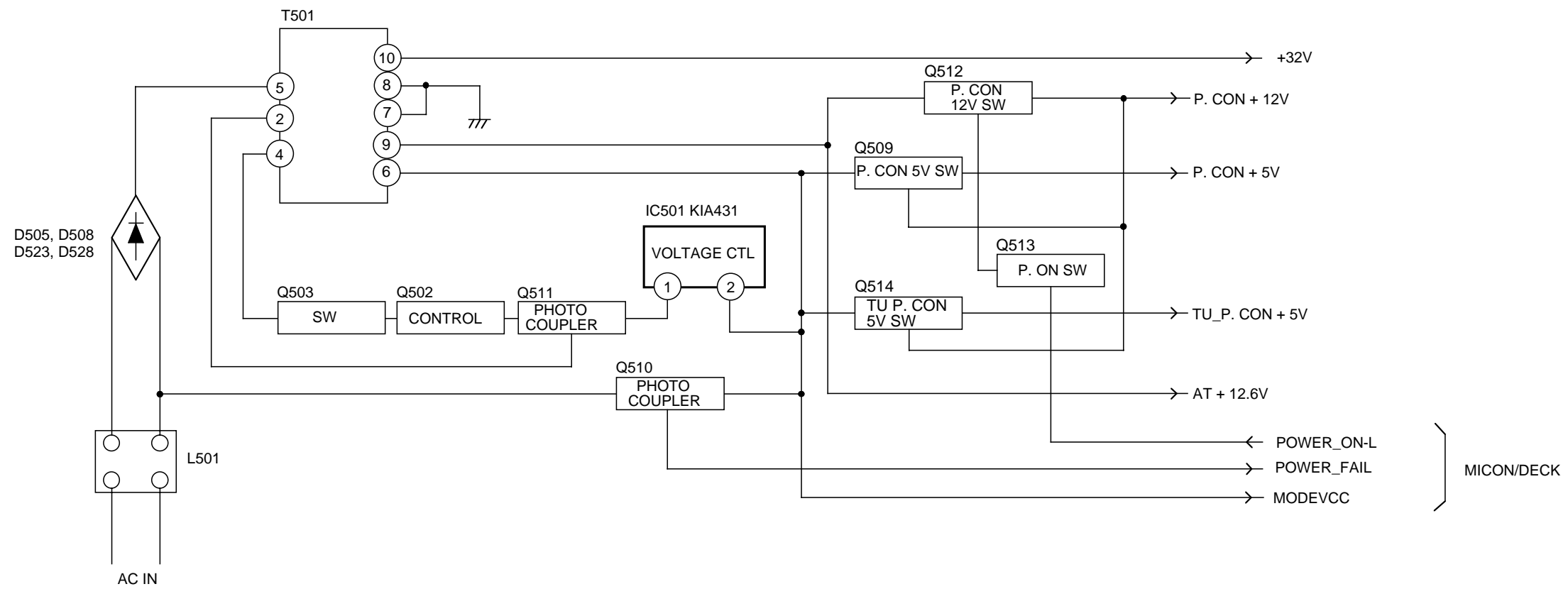

PRINTED CIRCUIT BOARDS
SYSCON /OPERATION (CHIP MOUNTED PARTS)
SOLDER SIDE

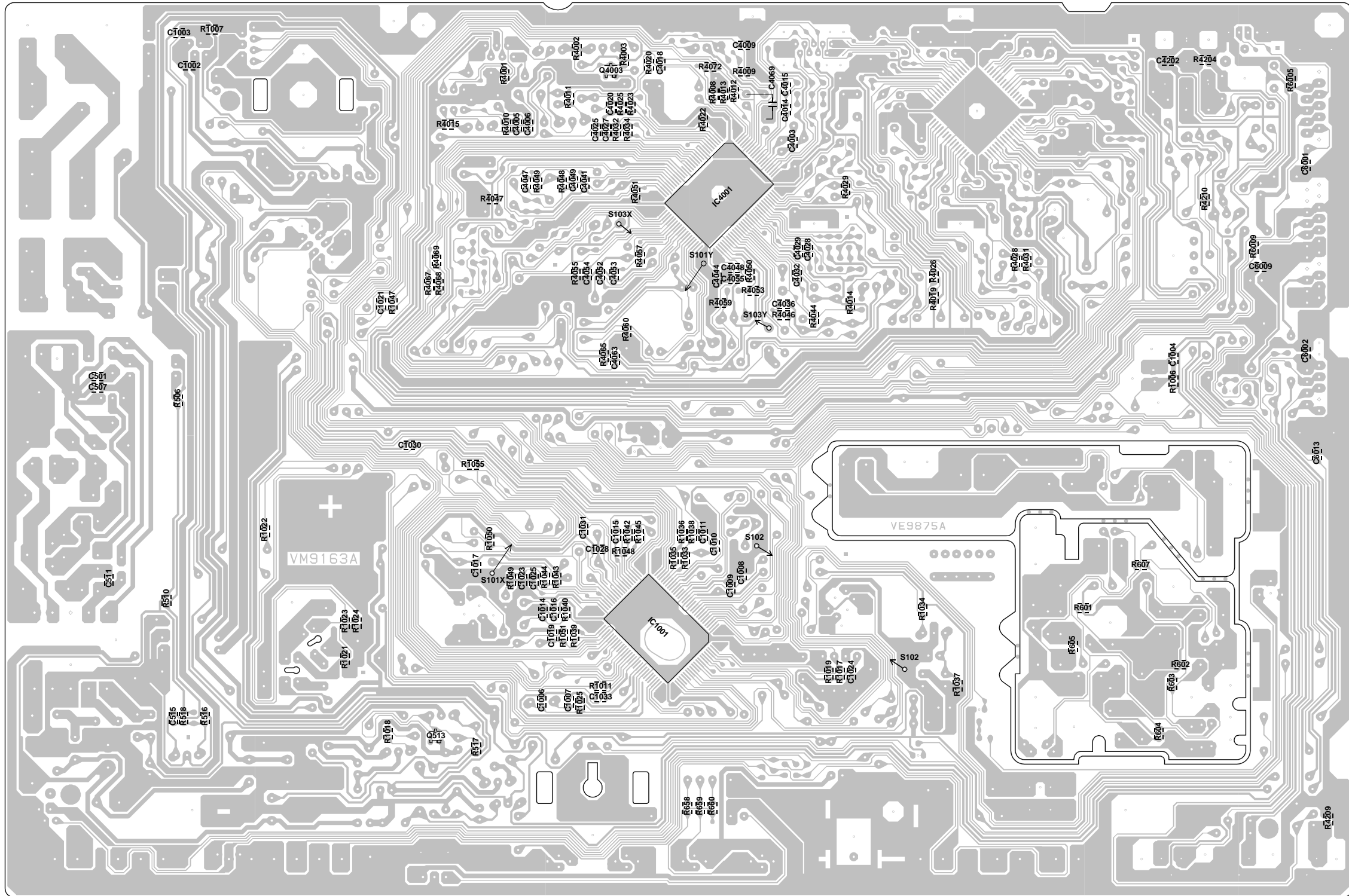

**PRINTED CIRCUIT BOARDS
DECK
SOLDER SIDE**

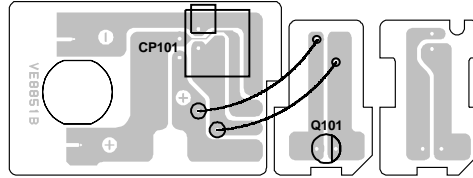

Y/C/AUDIO/HEAD AMP SCHEMATIC DIAGRAM

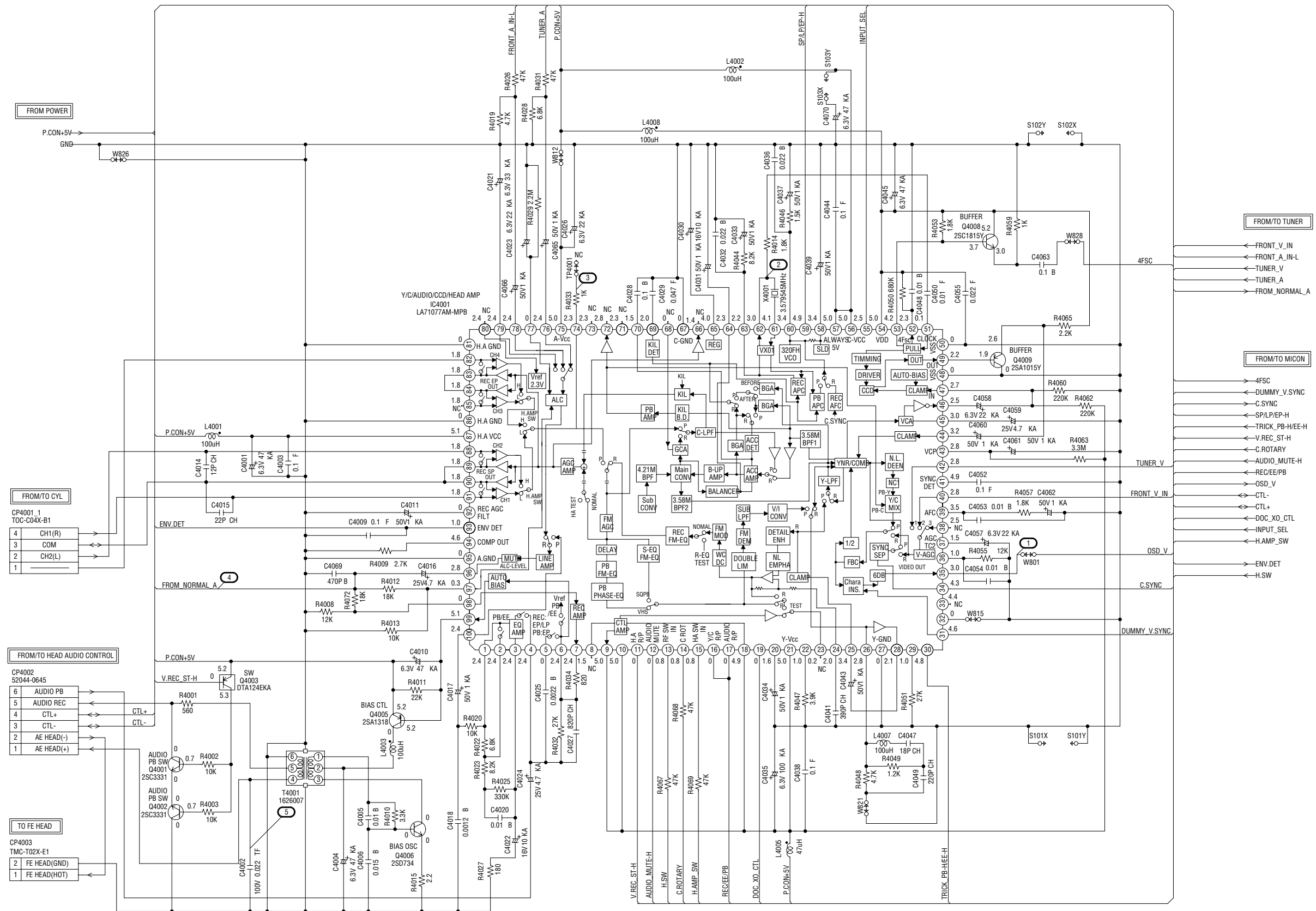

NOTE: THIS SCHEMATIC DIAGRAM IS THE LATEST AT THE TIME OF PRINTING AND SUBJECT TO CHANGE WITHOUT NOTICE.

NOTE: THE DC VOLTAGE AT EACH PART WAS MEASURED WITH THE DIGITAL TESTER DURING PLAYBACK.

CAUTION: DIGITAL TRANSISTOR

PCB010
VM9163

TUNER SCHEMATIC DIAGRAM

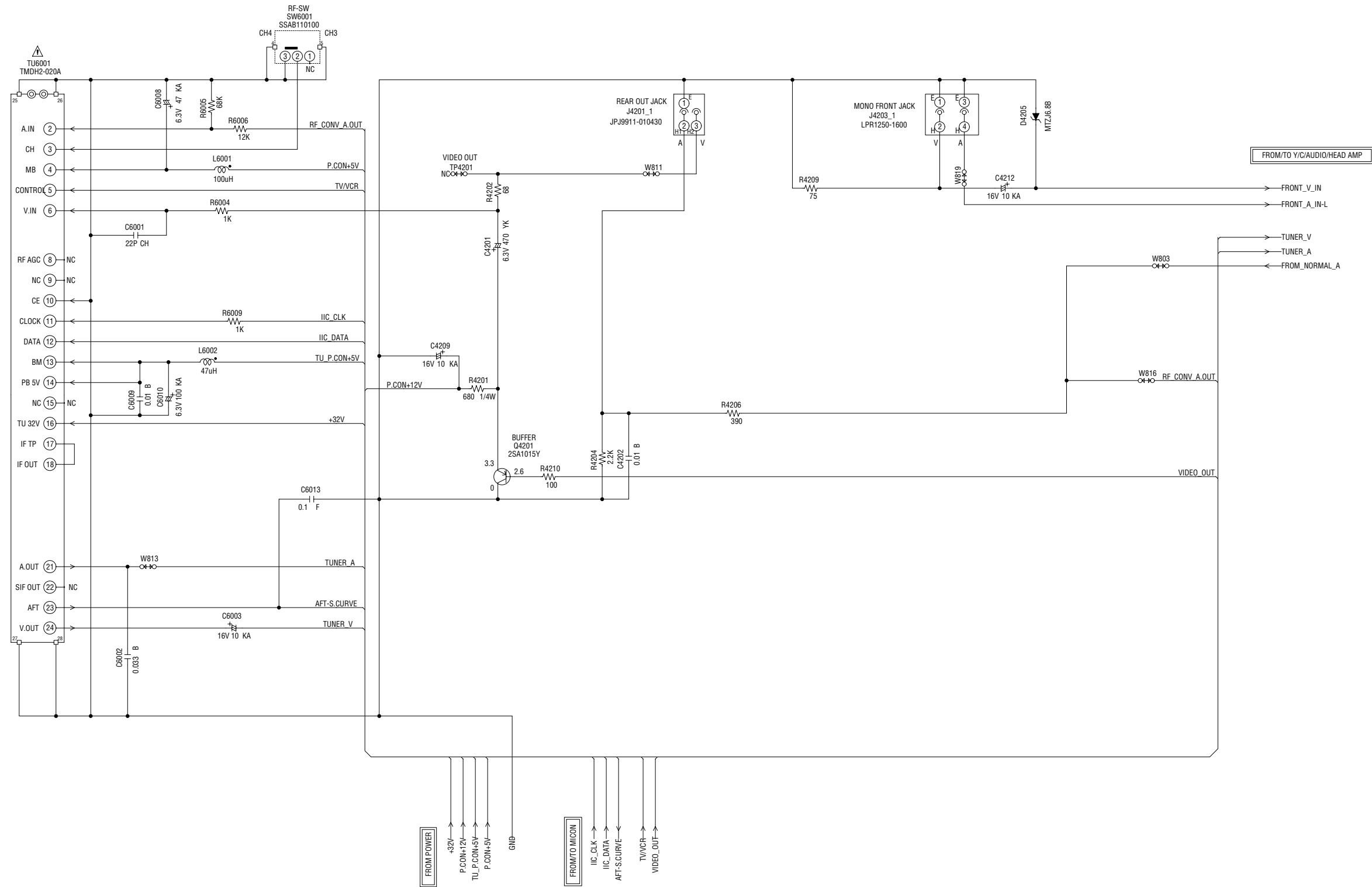

NOTE: THE DC VOLTAGE AT EACH PART WAS MEASURED WITH THE DIGITAL TESTER DURING PLAYBACK.

NOTE: THIS SCHEMATIC DIAGRAM IS THE LATEST AT THE TIME OF PRINTING AND SUBJECT TO CHANGE WITHOUT NOTICE.

CAUTION: SINCE THESE PARTS MARKED BY ARE CRITICAL FOR SAFETY, USE ONES DESCRIBED IN PARTS LIST ONLY.

ATTENTION: LES PIECES REPARÉES PAR UN ÉTANT DANGEREUSES AN POINT DE VUE SECURITE N'UTILISER QUE CELLS DECRITES DANS LA NOMENCLATURE DES PIECES.

PC8010
VM9163

POWER SCHEMATIC DIAGRAM

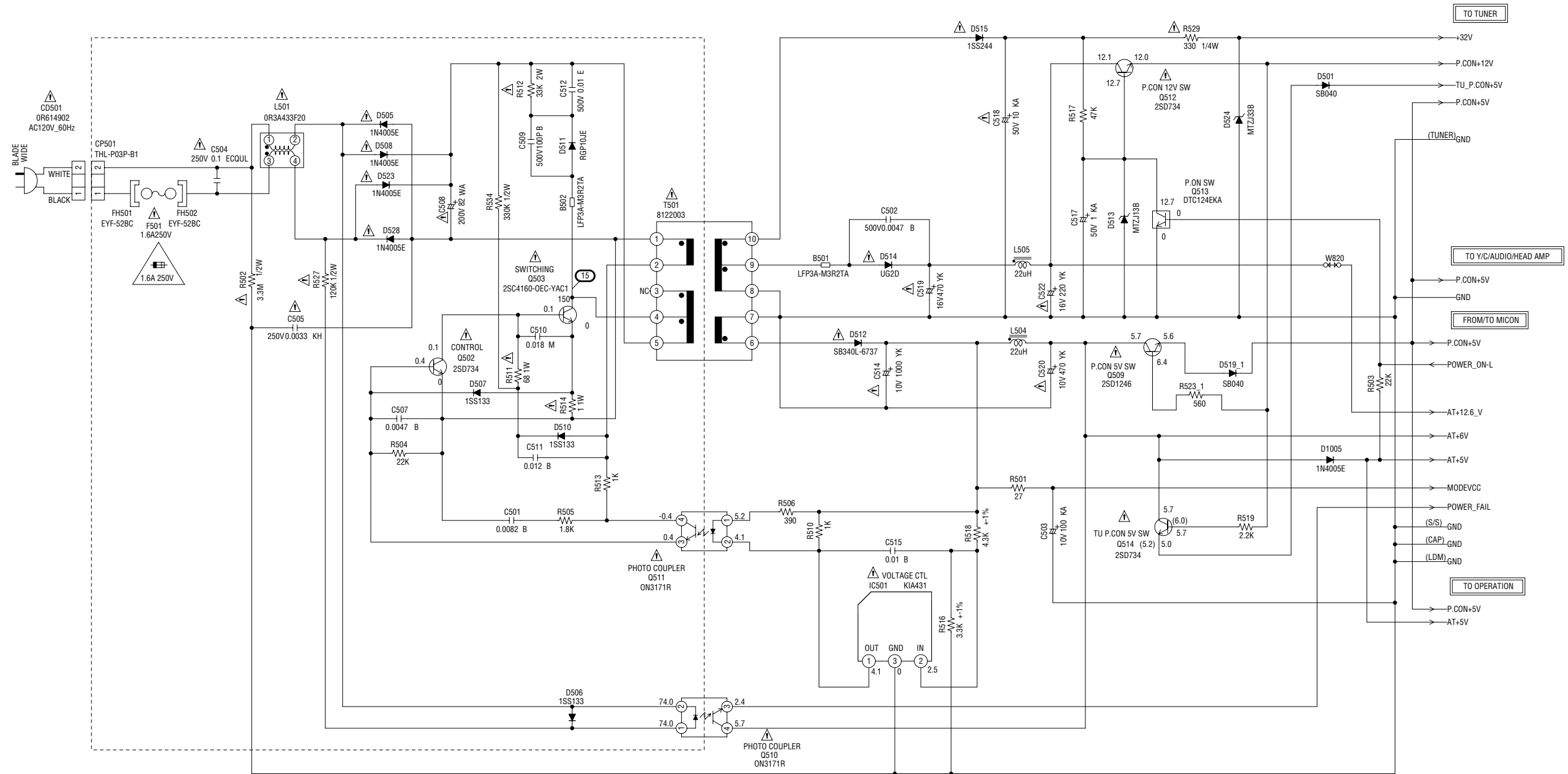

CAUTION: FOR CONTINUED PROTECTION AGAINST FIRE HAZARD, REPLACE ONLY WITH THE SAME TYPE FUSE 1.6A 250V (F501).
 ATTENTION: POUR UNE PROTECTION CONTINUE LES RISQUES D'INCENDIE N'UTILISER QUE DES FUSIBLES DE MEME TYPE 1.6A 250V (F501).

NOTE: THE DC VOLTAGE AT EACH PART WAS MEASURED WITH THE DIGITAL TESTER DURING PLAYBACK.

NOTE: THIS SCHEMATIC DIAGRAM IS THE LATEST AT THE TIME OF PRINTING AND SUBJECT TO CHANGE WITHOUT NOTICE.

ATTENTION: LES PIÈCES RÉPARÉES PAR UN ÉTANT DANGEREUSES AN POINT DE VUE SECURITE N'UTILISER QUE CELLES DECRITES DANS LA NOMENCLATURE DES PIÈCES.

CAUTION: SINCE THESE PARTS MARKED BY ARE CRITICAL FOR SAFETY USE ONES DESCRIBED IN PARTS LIST ONLY.

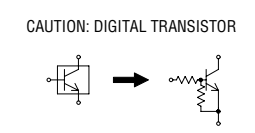

PCB010 VM9163

OPERATION SCHEMATIC DIAGRAM

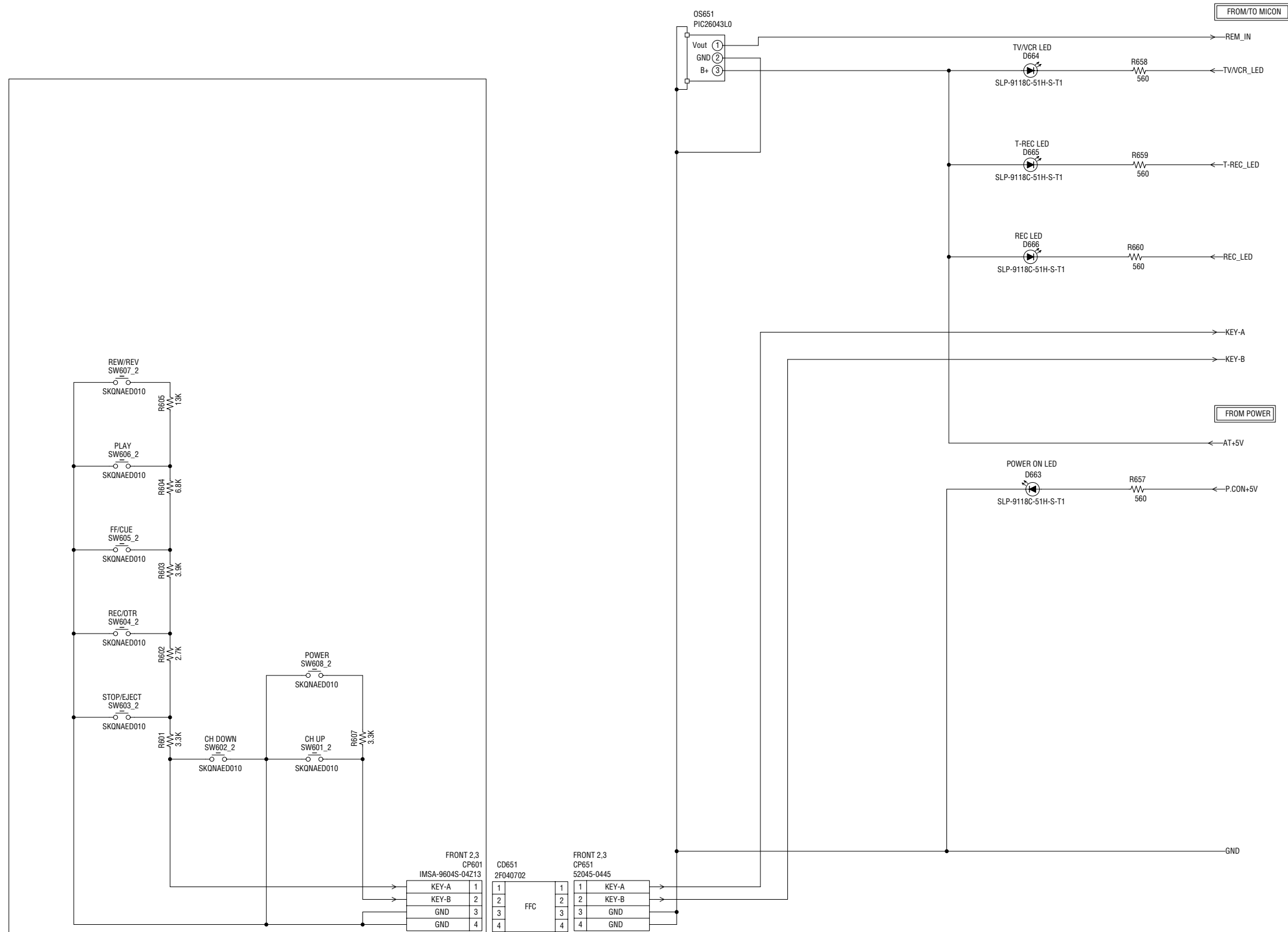

PCB270
VE9875

NOTE: THIS SCHEMATIC DIAGRAM IS THE LATEST AT THE TIME OF PRINTING AND SUBJECT TO CHANGE WITHOUT NOTICE.

NOTE: THE DC VOLTAGE AT EACH PART WAS MEASURED WITH THE DIGITAL TESTER DURING PLAYBACK.

PCB010
VM9163

DECK SCHEMATIC DIAGRAM

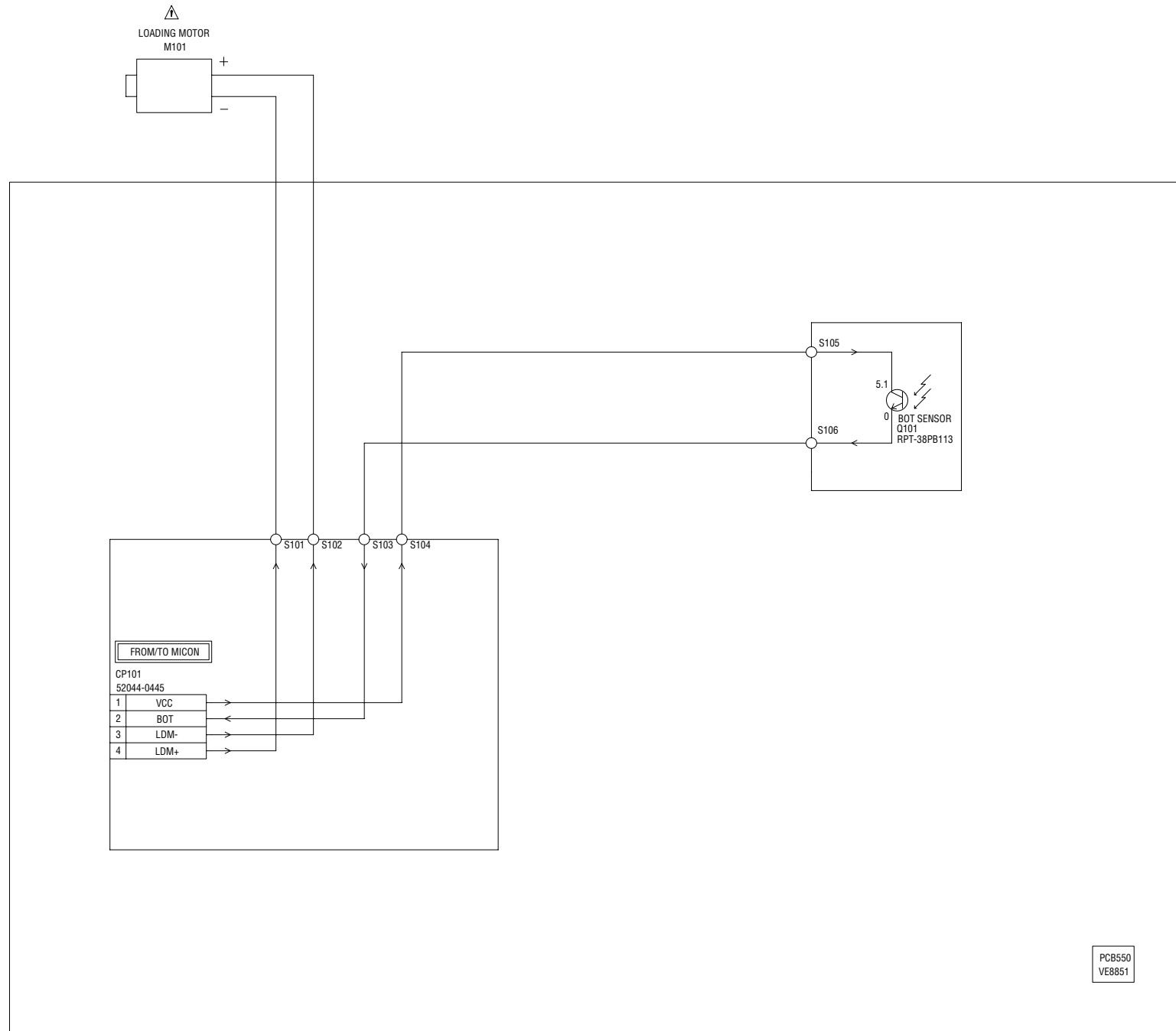

CAUTION: SINCE THESE PARTS MARKED BY  ARE CRITICAL FOR SAFETY USE ONES DESCRIBED IN PARTS LIST ONLY .

ATTENTION: LES PIECES REPARÉES PAR UN  ÉTANT DANGEREUSES AN POINT DE VUE SECURITE N'UTILISER QUE CELLS DECRITES DANS LA NOMENCLATURE DES PIECES.

NOTE: THE DC VOLTAGE AT EACH PART WAS MEASURED WITH THE DIGITAL TESTER DURING PLAYBACK.

NOTE: THIS SCHEMATIC DIAGRAM IS THE LATEST AT THE TIME OF PRINTING AND SUBJECT TO CHANGE WITHOUT NOTICE .

WAVEFORMS

Y/C/AUDIO/HEAD AMP

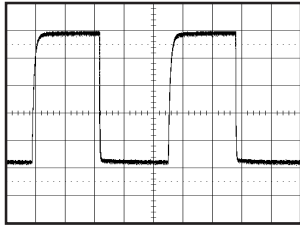

① PB
1V 0.2ms/div

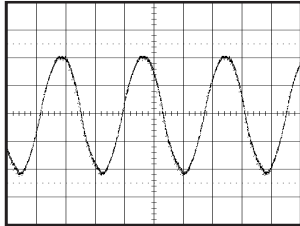

② POWER ON
100mV 0.1µs/div

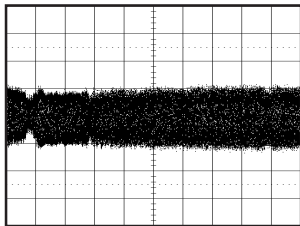

③ PB
200mV 1ms/div

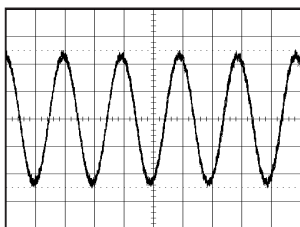

④ PB
200mV 0.5ms/div

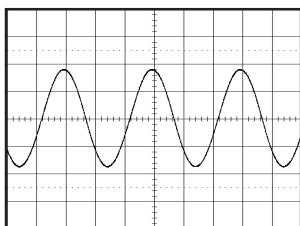

⑤ REC
20V 5µs/div

MICON

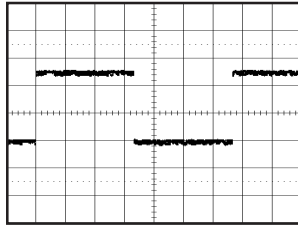

⑥ PB
2V 5ms/div

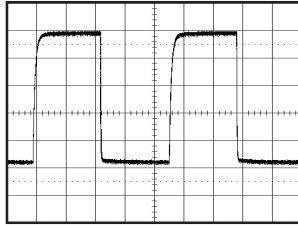

⑦ PB
1V 0.2ms/div

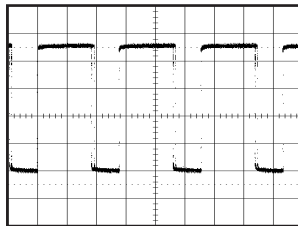

⑧ PB
1V 0.5ms/div

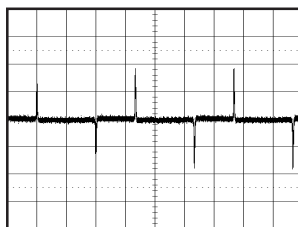

⑨ PB
0.5V 10ms/div

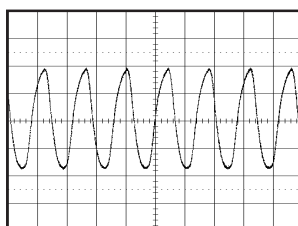

⑩ POWER ON
0.5V 50ns/div

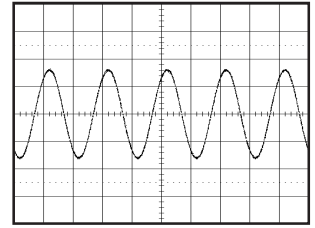

⑪ POWER ON
1V 50ns/div

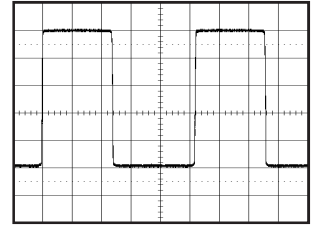

⑫ PB
1V 0.2s/div

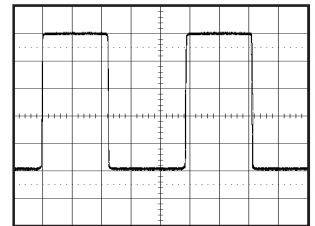

⑬ PB
1V 0.2s/div

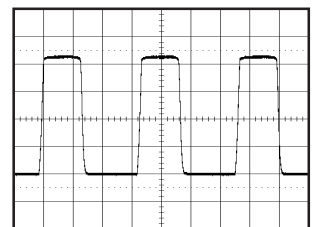

⑭ POWER ON
1V 5ms/div

POWER

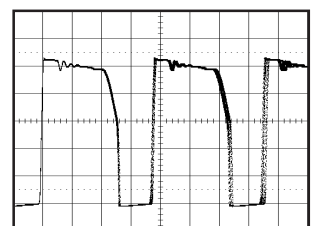

⑮ PB
50V 2µs/div

NOTE: The following waveforms were measured at the point of the corresponding balloon number in the schematic diagram.

MECHANICAL EXPLODED VIEW

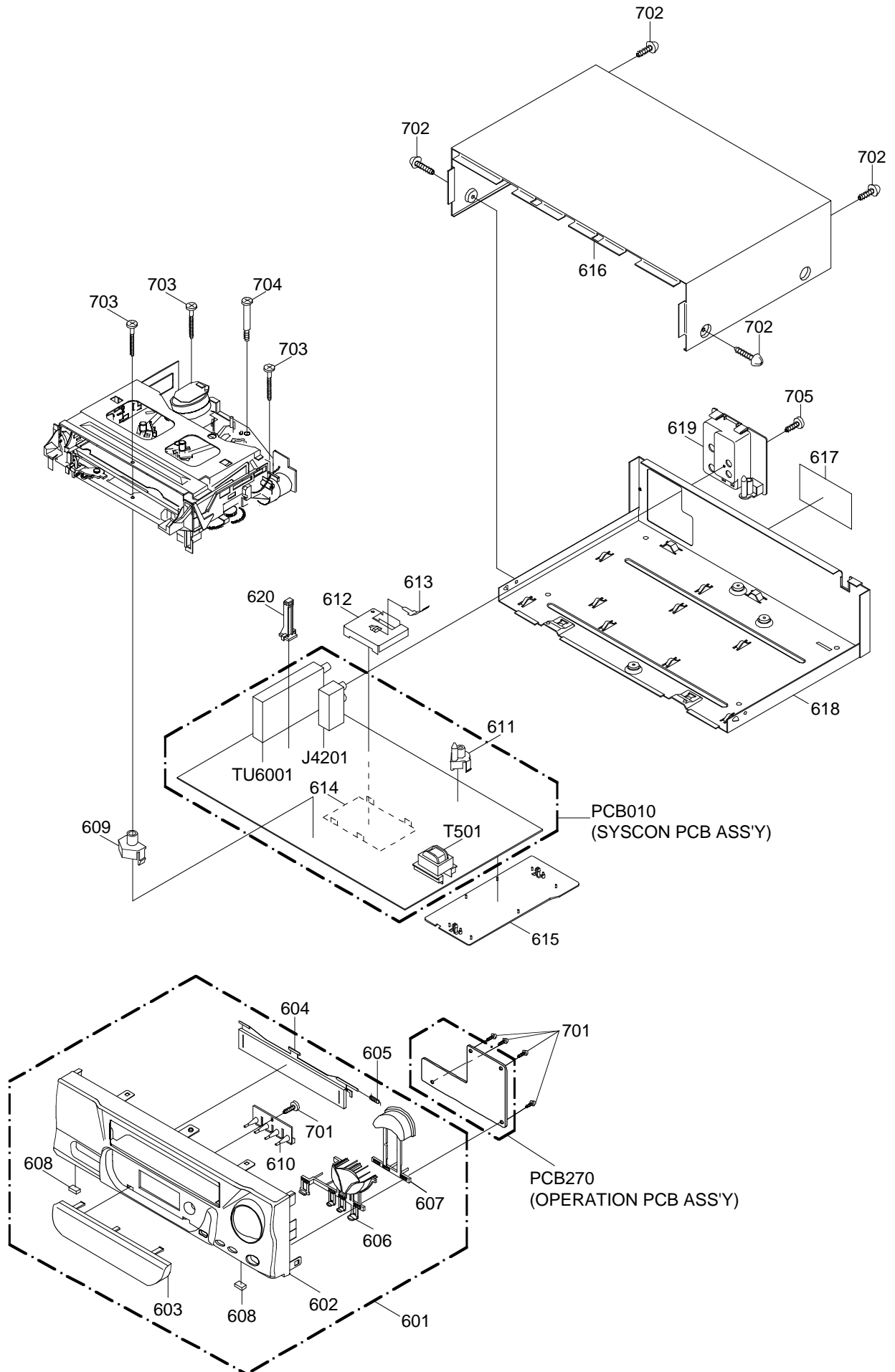

CHASSIS EXPLODED VIEW (TOP VIEW)

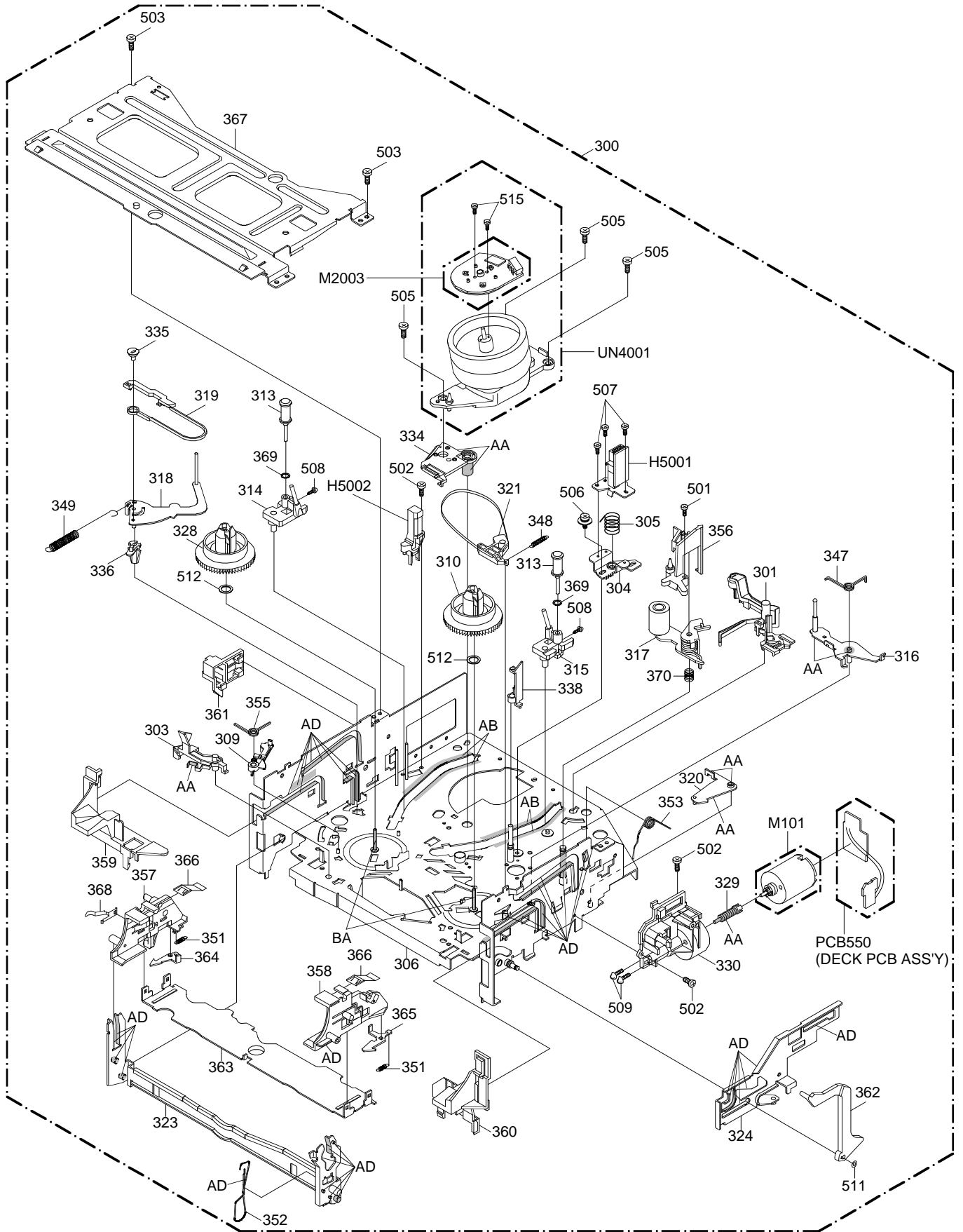

CLASS	PART NO.	MARK
GREASE	G-555G	AA
	G-488M	AB
	FL-721	AC
	MG-33	AD
OIL	FL OIL No. 6115	BA

NOTE: Applying positions AA, AB, AC, AD and BA for the grease or oil are displayed for this section. Check if the correct grease or oil is applied for each position.

CHASSIS EXPLODED VIEW (BOTTOM VIEW)

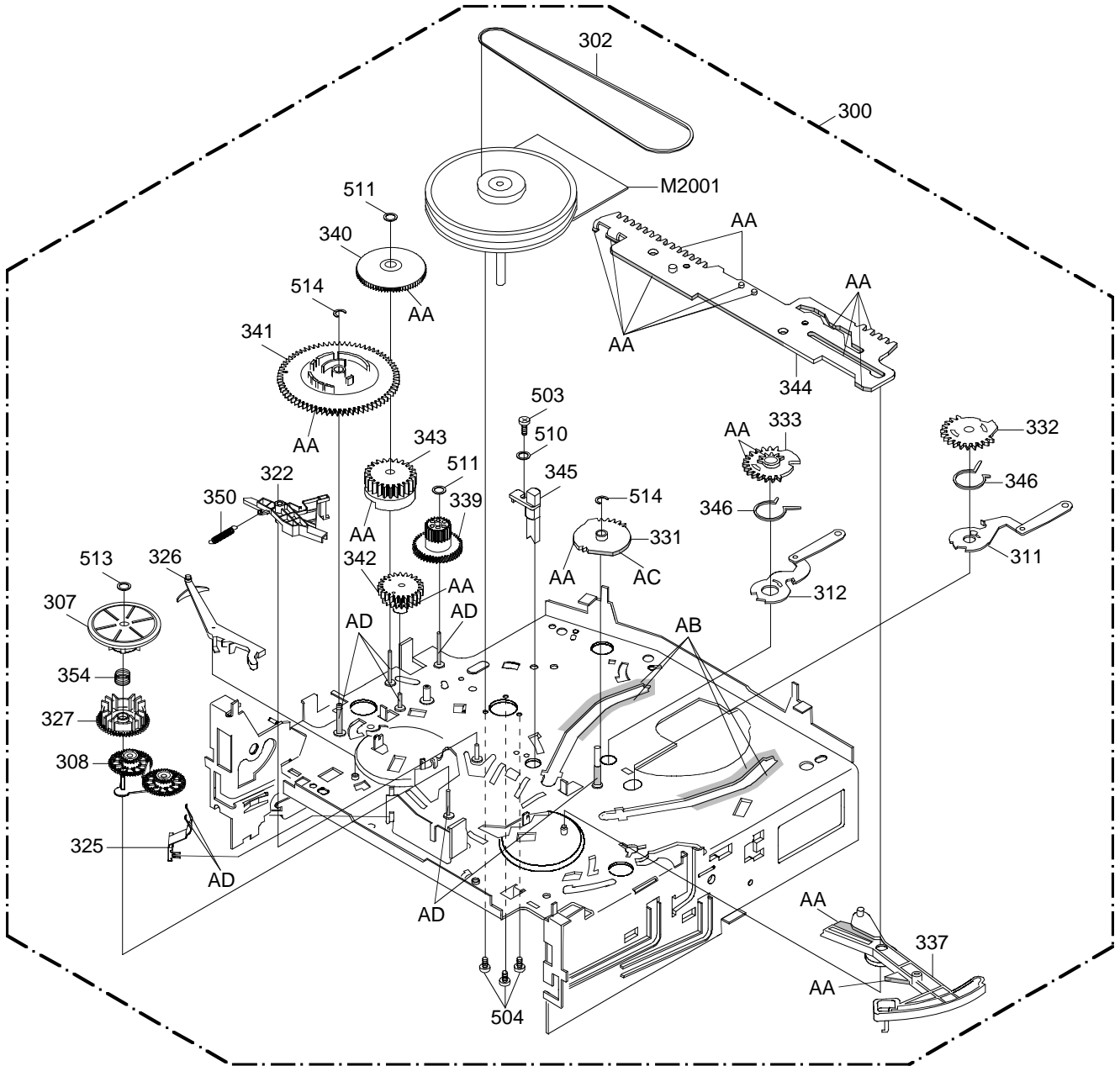

CLASS	PART NO.	MARK
GREASE	G-555G	AA
	G-488M	AB
	FL-721	AC
	MG-33	AD
OIL	FL OIL No. 6115	BA

NOTE: Applying positions AA, AB, AC, AD and BA for the grease or oil are displayed for this section. Check if the correct grease or oil is applied for each position.

MECHANICAL REPLACEMENT PARTS LIST

REF. NO.	PART NO.	DESCRIPTION
601	A4C732B720	CABINET,FRONT ASS'Y
602	701WPJA663	CABINET,FRONT
603	711WPDA232	PLATE,DISPLAY
604	712WPJA472	FLAP
605	743WKAA001	SPRING,FLAP
606	735WPDA258	BUTTON,DECK
607	735WPDA259	BUTTON,PLAY
608	800WFA0020	CUSHION,LEG
609	701WPA0423	HOLDER,DECK
610	713WPA0086	GLASS,LED
611	704WPA0007	HOLDER,DECK (R)
612	752WSA0144	SHIELD,CASE HEAD AMP
613	753WUA0051	SPRING,EARTH HEAD AMP
614	753WSA0124	SHIELD,COVER HEAD AMP
615	755WPA0015	PLATE,COVER POWER
616	702WSB0015	CABINET,TOP
617	722A08A030	SHEET,RATING
618	702WSA0059	PLATE,BOTTOM
619	702WPA0645	PLATE,JACK
620	85OP700036	HOLDER,EOT SENSOR
701	8110226084	SCREW,TAP TITE (P) BIND 2.6x8
702	8107240802	SCREW,TAP TITE (S) BIND 4x8
703	8107140B94	SCREW,TAP TITE (S) PAN 4x29
704	8146240644	SCREW,TAP TITE (S) BIND 4x6
705	8110230A02	SCREW,TAP TITE (P) BIND 3x10
---	JA5U0100	POLYBAG
---	J4C73201	INSTRUCTIONBOOK
---	791WHA0010	GIFT SHEET
---	792WHA0214	PACKAGE
---	793WCDA564	GIFT BOX

CHASSIS REPLACEMENT PARTS LIST

REF. NO.	PART NO.	DESCRIPTION	REF. NO.	PART NO.	DESCRIPTION
300	A4C731B420A	DECK ASSY A4C731B420A	501	8107126A04	SCREW,TAP TITE(S) PAN 2.6x10
301	85OA500022	AHC ASS'Y	502	8107226804	SCREW,TAP TITE(S) BIND 2.6x8
302	85OP200290	BELT,CAPSTAN (S)	503	8107226604	SCREW,TAP TITE(S) BIND 2.6x6
303	85OP900689	LEVER,REC	504	8109126604	SCREW,TAP TITE(B) PAN 2.6x6
304	85OP500083	BASE,AC HEAD	505	810A126804	SCREW/WASHER(A) M2.6x8
305	85OP800324	SPRING,AC HEAD	506	810B126404	SCREW/WASHER(B) M2.6x4
306	85OA000305	MAIN CHASSIS ASS'Y (S)	507	8102120604	SCREW,PAN M2x6
307	85OA200077	CLUTCH ASS'Y (S)	508	8102120304	SCREW,PAN M2x3
308	85OA200080	ARM,IDLER ASS'Y (S)	509	8102130304	SCREW,PAN M3.0x3.0
309	85OP600556	ARM,SS BRAKE (S)	510	82A2675051	WASHER 2.6x7.5xT0.5
310	85OP200292	REEL,T (S)	511	82P266005N	POLYSLIDER WASHER(CUT) 2.6x6.0xT0.5
311	85OA300061	LOADING ARM S ASS'Y	512	82Q2647C5N	POLYSLIDER WASHER 2.6x4.7xT0.25
312	85OA300062	LOADING ARM T ASS'Y	513	82P184505N	POLYSLIDER WASHER(CUT) 1.8x4.5xT0.5
313	85OA400182	GUIDE ROLLER ASS'Y	514	83ETW30000	E-RING 3.0
314	85OA400188	BASE,INCL S ASS'Y	515	810A123504	SEMS A M2.3x5.0
315	85OA400196	BASE,INCL T(S) ASS'Y	CP101	069R740018	CONNECTOR PCB SIDE 52044-0445
316	85OA400199	P5-3 ARM ASS'Y(S)	H5001	1523D91034	HEAD (AUDIO CONTROL) HVMXA1072A
317	85OA400174	PINCH ROLLER BLOCK	H5002	1543D02013	HEAD (FULL ERASE) HVFHP0032A
318	85OA400175	TENSION ARM ASS'Y	△ M101	85OA600190	LOADING MOTOR ASS'Y
319	85OA400184	TENSION BAND ASS'Y (S)	△ M2001	1510398030	CAPSTAN DD UNIT F2QSB02
320	85OA400178	PINCH ROLLER LEVER ASS'Y	M2003	1589311005	MICRO MOTOR F2OEL82
321	85OA600188	BRAKE T ASS'Y (S)	PCB550	A4C831B550	DECK PCB ASS'Y VE8851
322	85OA600191	CAP BRAKE ASS'Y(S)	Q101	0000700320	TRANSISTOR,PHOTO RPT-38PB113
323	85OA900213	LINK ASS'Y	△ UN4001	A4C701B500	CYLINDER UNIT ASS'Y A4C701B500
324	85OA900216	LINK LEVER ASS'Y			
325	85OP200284	LEVER,CLUTCH (S)			
326	85OP200285	ACTUATOR,CLUTCH			
327	85OP200286	GEAR,COUPLING			
328	85OP200291	REEL,S (S)			
329	85OP600541	WORM			
330	85OP600542	BRACKET,MOTOR			
331	85OP300178	GEAR,MAIN LOADING			
332	85OP300179	GEAR,LOADING S			
333	85OP300180	GEAR,LOADING T			
334	85OP300186	HOLDER,LOADING GEAR			
335	85OP400472	ADJUST,TENSION			
336	85OP400492	HOLDER,TENSION			
337	85OP400490	LEVER,TENSION			
338	85OP400475	COVER,P4			
339	85OP600543	GEAR,JOINT			
340	85OP600544	GEAR,MIDDLE			
341	85OP600554	CAM,MAIN (S)			
342	85OP600546	CAM,P5			
343	85OP600547	CAM,PINCH ROLLER			
344	85OP600561	ROD,MAIN(S)			
345	85OP700035	REFLECTOR,LED			
346	85OP800318	SPRING,LOADING GEAR			
347	85OP800334	SPRING,P5 (S)			
348	85OP800335	SPRING,BRAKE T (S)			
349	85OP800322	SPRING,TENSION			
350	85OP800336	SPRING,CAP BRAKE (S)			
351	85OP800325	SPRING,LOCKER			
352	85OP800326	SPRING,LINK			
353	85OP800328	SPRING,DAMPER			
354	85OP800330	SPRING,RING			
355	85OP800337	SPRING,SS BRAKE (S)			
356	85OP900680	OPENER,CASS			
357	85OP900683	CASS SIDE L			
358	85OP900684	CASS SIDE R			
359	85OP900702	TAPE GUIDE L(P,R)			
360	85OP900686	TAPE GUIDE R			
361	85OP900703	COVER,SENSOR L2			
362	85OP900688	LEVER,FLAP			
363	85OP900690	CASS HOLDER			
364	85OP900691	LOCKER,L			
365	85OP900692	LOCKER,R			
366	85OP900694	SPRING,PACK			
367	85OP900695	BRACKET,TOP			
368	85OP900696	SPRING,CASS EARTH			
369	85OP400485	O-RING			
370	85OP800341	SPRING,P/R ARM			

ELECTRICAL REPLACEMENT PARTS LIST

REF. NO.	PART NO.	DESCRIPTION	REF. NO.	PART NO.	DESCRIPTION
RESISTORS					
△ R502	R0G3K2335K	RC			3.3M OHM 1/2W
△ R511	R3X181680J	R, METAL OXIDE			68 OHM 1W
△ R512	R3X28A333J	R, METAL OXIDE			33K OHM 2W
△ R514	R3X181010J	R, METAL OXIDE			1 OHM 1W or
	R3U181010J	R, METAL OXIDE			1 OHM 1W
△ R527	R0X2X2124J	RC			120K OHM 1/2W
△ R529	R61584331J	R, FUSE			330 OHM 1/4W
△ R1002	R3X1812R7J	R, METAL OXIDE			2.7 OHM 1W
CAPACITORS					
△ C504	P2122B104M	CMP			0.1 UF 250V ECQUL
△ C505	CB3LE0ML3M	CC			0.0033UF 250V
△ C508	E02AFC820M	CE			82 UF 200V
C512	COJFE0514M	CC			0.01 UF 500V E
△ C514	E02LT1102M	CE			1000 UF 10V
△ C518	E50HU5100M	CE			10 UF 50 V
△ C519	E02LT2471M	CE			470 UF 16V
△ C520	E02LU1471M	CE			470 UF 10V
△ C522	E02LT2221M	CE			220 UF 16V
C4069	CHG0B04Q2K	CC			470 PF 50V B
DIODES					
D501	D23TSB0400	DIODE, SILICON			SB040-G3
△ D505	D2LXE65800	DIODE, SILICON			1N4005E-G23
D506	D1VT001330	DIODE, SILICON			1SS133T-77
D507	D1VT001330	DIODE, SILICON			1SS133T-77
△ D508	D2LXE65800	DIODE, SILICON			1N4005E-G23
D510	D1VT001330	DIODE, SILICON			1SS133T-77
D511	D2LTP10JE0	DIODE, RECTIFIER			RGP10JE-G3
△ D512	D2LKB340L0	DIODE, SCHOTTKY			SB340L-6737
D513	D97U01301B	DIODE, ZENER			MTZJ13B T-77
△ D514	D23T0UG2D0	DIODE, SILICON			UG2D-G23
△ D515	D17T002440	DIODE, SILICON			1SS244T-77
D519	D23TSB0400	DIODE, SILICON			SB040-G3
△ D523	D2LXE65800	DIODE, SILICON			1N4005E-G23
D524	D97U03301B	DIODE, ZENER			MTZJ33B T-77
△ D528	D2LXE65800	DIODE, SILICON			1N4005E-G23
D663	0021320220	LED			SLP-9118C-51H-S-T1
D664	0021320220	LED			SLP-9118C-51H-S-T1
D665	0021320220	LED			SLP-9118C-51H-S-T1
D666	0021320220	LED			SLP-9118C-51H-S-T1
D1001	0010600060	LED			SID1050CM
D1002	D2LXE65800	DIODE, SILICON			1N4005E-G23
D1003	D93T11201A	DIODE, ZENER			TMPG06-12A
D1004	D2LXE65800	DIODE, SILICON			1N4005E-G23
D1005	D2LXE65800	DIODE, SILICON			1N4005E-G23
D1006	D1VT001330	DIODE, SILICON			1SS133T-77
D1007	D1VT001330	DIODE, SILICON			1SS133T-77
D1008	D1VTB721Q0	DIODE, SCHOTTKY			RB721QT-77
D4205	D97U06R81B	DIODE, ZENER			MTZJ6.8B T-77 or
	D97U06R81C	DIODE, ZENER			MTZJ6.8C T-77 or
	D94TA6R2J2	DIODE, ZENER			HZS6R2JB2-TE
ICs					
△ IC501	I1KJ9A4310	IC			KIA431
IC1001	I54F50080A	IC			OEC0080A
△ IC1002	I07SQ955AN	IC			BA6955AN
IC1003	IE1J0S31AH	IC			RE5VS31A
IC1099	A4C732B015	IC			M24C01-BN6
IC4001	I03F310770	IC			LA71077AM-MPB
TRANSISTORS					
△ Q502	TD3T007340	TRANSISTOR, SILICON			2SD734(E,F)-AA
△ Q503	TCWQ4160E0	TRANSISTOR, SILICON			2SC4160-OEC-YAC11
△ Q509	TD3T012460	TRANSISTOR, SILICON			2SD1246(S,T)-AA
△ Q510	000210001R	PHOTO COUPLER			ON3171R
△ Q511	000210001R	PHOTO COUPLER			ON3171R
△ Q512	TD3T007340	TRANSISTOR, SILICON			2SD734(E,F)-AA
Q513	TNYJC05001	COMPOUND TRANSISTOR			DTC124EKAT146
△ Q514	TD3T007340	TRANSISTOR, SILICON			2SD734(E,F)-AA
Q1001	0002G00540	PHOTO COUPLER			GP1S566
Q1002	0002G00540	PHOTO COUPLER			GP1S566
Q1003	TC5T018154	TRANSISTOR, SILICON			2SC1815Y(TPE2)
Q1004	0002G00550	PHOTO COUPLER			GP1S94L
Q1005	0002G00550	PHOTO COUPLER			GP1S94L
Q1006	0000100380	PHOTO TRANSISTOR			PNA2604M010R
Q4001	TC3T033310	TRANSISTOR, SILICON			2SC3331(S,T,U)-A
Q4002	TC3T033310	TRANSISTOR, SILICON			2SC3331(S,T,U)-A
Q4003	TPYJC05001	COMPOUND TRANSISTOR			DTA124EKAT146
Q4005	TA3T013180	TRANSISTOR, SILICON			2SA1318(S,T)-AA
Q4006	TD3T007340	TRANSISTOR, SILICON			2SD734(E,F)-AA
TRANSISTORS					
Q4008	TC5T018154	TRANSISTOR, SILICON			2SC1815Y(TPE2)
Q4009	TA5T010154	TRANSISTOR, SILICON			2SA1015Y(TPE2)
Q4201	TA5T010154	TRANSISTOR, SILICON			2SA1015Y(TPE2)
COILS & TRANSFORMERS					
△ L501	029T000083	COIL, LINE FILTER			0R3A433F20
L504	021W66220M	COIL, CHOKE			22 UH
L505	021W66220M	COIL, CHOKE			22 UH
L1001	021LA6150K	COIL			15 UH
L4001	02167F101J	COIL			100 UH
L4002	02167F101J	COIL			100 UH
L4003	021673101J	COIL			100 UH
L4005	02167F470J	COIL			47 UH
L4007	021LA6101K	COIL			100 UH
L4008	02167F101J	COIL			100 UH
L6001	02167F101J	COIL			100 UH
L6002	02167F470J	COIL			47 UH
△ T501	0481220034	TRANSFORMER, SWITCHING			8122003
T4001	031626007S	COIL, BIAS OSC			1626007
JACKS					
J4201	0602401029	RCA, JACK			JPJ9911-010430
J4203	0607401023	RCA, JACK			LPR1250-1600
SWITCHES					
SW601	0504201T32	SWITCH, TACT			SKQNAED010
SW602	0504201T32	SWITCH, TACT			SKQNAED010
SW603	0504201T32	SWITCH, TACT			SKQNAED010
SW604	0504201T32	SWITCH, TACT			SKQNAED010
SW605	0504201T32	SWITCH, TACT			SKQNAED010
SW606	0504201T32	SWITCH, TACT			SKQNAED010
SW607	0504201T32	SWITCH, TACT			SKQNAED010
SW608	0504201T32	SWITCH, TACT			SKQNAED010
SW1001	0508221001	SWITCH (LEAF)			SPVF130100
SW6001	0501201010	SWITCH, SLIDE			SSAB110100
VARIABLE RESISTORS					
VR1001	V126314BTC	VOLUME, SEMI FIXED			RH063MC14R or
	V126314BT7	VOLUME, SEMI FIXED			RH0683C14R
P.C. BOARD ASSEMBLIES					
PCB010	A4C732B01A	PCB ASS'Y			VM9163A
PCB270	A4C732B27A	PCB ASS'Y			VE9875A
PCB550	A4C831B550	SEE CHASSIS REPLACEMENT PARTS LIST			
MISCELLANEOUS					
B501	024DT03581	CORE, BEADS			LFP3A-M3R2TA
B502	024DT03581	CORE, BEADS			LFP3A-M3R2TA
△ CD501	120R614902	CORD, AC			U4N 0R614902
CD651	122F040702	CORD, JUMPER			2F040702 or
	122S040703	CORD, JUMPER			2S040703
CP501	0697320039	CORD, UX CONNECTOR			THL-P03P-B1
CP601	069J740019	CONNECTOR PCB SIDE			IMSA-9604S-04Z13
CP651	069R740028	CONNECTOR PCB SIDE			52045-0445
CD1001	122F040702	CORD, JUMPER			2F040702 or
	122S040703	CORD, JUMPER			2S040703
CD1002	122F061501	CORD, JUMPER			2F061501 or
	122S061401	CORD, JUMPER			1.25X6X138XC
CD4001	122F071701	CORD, JUMPER			2F071701 or
	122S071702	CORD, JUMPER			1.25X7X170XC
CD6002	06CQL02001	CABLE			SI-C108-38
CP1001	069R770028	CONNECTOR PCB SIDE			52045-0745
CP1002	0697280590	CONNECTOR PCB SIDE			TMC-J08P-B1
CP1003	069R740028	CONNECTOR PCB SIDE			52045-0445
CP4001	0697240600	CONNECTOR PCB SIDE			TOC-C04X-B1
CP4002	069R760018	CONNECTOR PCB SIDE			52044-0645
CP4003	0697120320	CONNECTOR PCB SIDE			TMC-T02X-E1
CUS011	800WF00004	CUSHION-A			
△ F501	080PA1R601	FUSE			23301.6-MB000
FH501	06710T0006	HOLDER, FUSE			EYF-52BC
FH502	06710T0006	HOLDER, FUSE			EYF-52BC
OS651	077Q000018	REMOTE RECEIVER			PIC26043LO
TM601	076R0CE030	TRANSMITTER			R25-1172
△ TU6001	0162600016	RF UNIT			TMDH2-020A
X1001	100CT01002	CRYSTAL HC-49/U-S			10MHz
X4001	100CF3R512	CRYSTAL HC-49/U			3.579545MHz

ELECTRICAL REPLACEMENT PARTS LIST

RESISTOR

RC..... CARBON RESISTOR

CAPACITORS

CC..... CERAMIC CAPACITOR

CE..... ALUMI ELECTROLYTIC CAPACITOR

CP..... POLYESTER CAPACITOR

CPP..... POLYPROPYLENE CAPACITOR

CPL..... PLASTIC CAPACITOR

CMP..... METAL POLYESTER CAPACITOR

CMPL..... METAL PLASTIC CAPACITOR

CMPP..... METAL POLYPROPYLENE CAPACITOR

SPEC.NO.	M4C7-32B
O/R NO.	B984005